



.....
Cheetah X15 36LP Disc Drive:
.....

ST336752LW/LC, ST336732LW/LC
.....

ST318452LW/LC, ST318432LW/LC
.....

.....
Product Manual, Volume 1

.....
Cheetah X15 36LP Disc Drive:
.....

ST336752LW/LC, ST336732LW/LC
.....

ST318452LW/LC, ST318432LW/LC
.....

.....
Product Manual, Volume 1
.....

Cheetah.

©2001, 2002 Seagate Technology LLC All rights reserved
Publication number: 100139872, Rev. D
June 2002

Seagate, Seagate Technology, and the Seagate logo are registered trademarks of Seagate Technology LLC. Cheetah, SeaFAX, SeaFONE, SeaBOARD, and SeaTDD are either registered trademarks or trademarks of Seagate Technology LLC. Other product names are registered trademarks or trademarks of their owners.

Seagate reserves the right to change, without notice, product offerings or specifications. No part of this publication may be reproduced in any form without written permission of Seagate Technology LLC.

Revision status summary sheet

Revision	Date	Writer/Engineer	Sheets Affected
Rev. A	06/27/01	L. Newman/J. Nowitzke	All.
Rev. B	11/30/01	L. Newman/B. Hohn	Pages 27, 36, 38, 39, and 56.
Rev. C	02/08/02	L. Newman/B. Hohn	Pages 5, 51 and 52.
Rev. D	06/04/02	L. Newman/B. Hohn	Pages 4, 67-70, 73-75.

Notice.

Product Manual 100139872 is Volume 1 of a two volume document with the SCSI Interface information in the Volume 2 SCSI Interface Product Manual, part number 75789509.

If you need the SCSI Interface information, order the Volume 2 Interface Manual, part number 75789509.

Contents

1.0	Scope	1
2.0	Applicable standards and reference documentation	3
2.1	Standards	3
	2.1.1 Electromagnetic compatibility	3
	2.1.2 Electromagnetic susceptibility	3
2.2	Electromagnetic compliance	3
2.3	Reference documents	4
3.0	General description	5
3.1	Standard features	6
3.2	Media characteristics	6
3.3	Performance	6
3.4	Reliability	6
3.5	Unformatted and formatted capacities	7
3.6	Programmable drive capacity	7
3.7	Factory installed accessories	7
3.8	Options (factory installed)	7
3.9	Accessories (user installed)	7
4.0	Performance characteristics	8
4.1	Internal drive characteristics (transparent to user)	8
4.2	SCSI performance characteristics (visible to user)	8
	4.2.1 Access time [5]	8
	4.2.2 Format command execution time (minutes) [1]	8
	4.2.3 Generalized performance characteristics	8
4.3	Start/stop time	9
4.4	Prefetch/multi-segmented cache control	9
4.5	Cache operation	9
	4.5.1 Caching write data	10
	4.5.2 Prefetch operation	11
	4.5.3 Optimizing cache performance for desktop and server applications	11
5.0	Reliability specifications	13
5.1	Error rates	13
	5.1.1 Environmental interference	13
	5.1.2 Read errors	13
	5.1.3 Write errors	13
	5.1.4 Seek errors	13
5.2	Reliability and service	14
	5.2.1 Mean time between failure	14
	5.2.2 Preventive maintenance	14
	5.2.3 Service life	14
	5.2.4 Service philosophy	14
	5.2.5 Service tools	14
	5.2.6 Hot plugging Cheetah X15 36LP disc drives	15
	5.2.7 S.M.A.R.T.	15
	5.2.8 Thermal Monitor	16
	5.2.9 Drive Self Test (DST)	17
	5.2.10 Product warranty	19
6.0	Physical/electrical specifications	21
6.1	AC power requirements	21
6.2	DC power requirements	21
	6.2.1 Conducted noise immunity	22
	6.2.2 Power sequencing	22
	6.2.3 12 V - Current profile	22
6.3	Power dissipation	25

6.4	Environmental limits27
6.4.1	Temperature27
6.4.2	Relative humidity27
6.4.3	Effective altitude (sea level)27
6.4.4	Shock and vibration28
6.4.5	Air cleanliness30
6.4.6	Acoustics30
6.4.7	Electromagnetic susceptibility30
6.5	Mechanical specifications31
7.0	Defect and error management33
7.1	Drive internal defects33
7.2	Drive error recovery procedures33
7.3	SCSI systems errors34
8.0	Installation35
8.1	Drive ID/option select header35
8.1.1	Notes for Figures 14, 15, and 16.38
8.1.2	Function description39
8.2	Drive orientation40
8.3	Cooling40
8.4	Drive mounting41
8.5	Grounding41
9.0	Interface requirements43
9.1	General description43
9.2	SCSI interface messages supported43
9.3	SCSI interface commands supported44
9.3.1	Inquiry Vital Product data47
9.3.2	Mode Sense data48
9.4	SCSI bus conditions and miscellaneous features supported53
9.5	Synchronous data transfer54
9.5.1	Synchronous data transfer periods supported54
9.5.2	REQ/ACK offset54
9.6	Physical interface54
9.6.1	DC cable and connector55
9.6.2	SCSI interface physical description57
9.6.3	SCSI interface cable requirements58
9.6.4	Mating connectors59
9.7	Electrical description67
9.7.1	Multimode—SE and LVD alternatives67
9.8	Terminator requirements70
9.9	Terminator power70
9.10	Disc drive SCSI timing71
9.11	Drive activity LED72
10.0	Seagate Technology support services73

List of Figures

Figure 1.	Cheetah X15 36LP family drive (ST336752LC shown)	1
Figure 2.	Typical ST336752 and ST336732 drive +12 V current profile	22
Figure 3.	Typical ST336752 and ST336732 drive +5 V current profile.	23
Figure 4.	Typical ST318452 and ST318432 drive +12 V current profile	23
Figure 5.	Typical ST318452 and ST318432 drive +5 V current profile.	24
Figure 6.	ST336752 and ST336732 DC current and power vs. IOPS (SE)	25
Figure 7.	ST336752 and ST336732 DC current and power vs. IOPS (LVD)	25
Figure 8.	ST318452 and ST318432 DC current and power vs. IOPS (SE)	26
Figure 9.	ST318452 and ST318432 DC current and power vs. IOPS (LVD)	26
Figure 10.	Locations of the HDA temperature check point	27
Figure 11.	Recommended mounting	29
Figure 12.	LW mounting configuration dimensions	31
Figure 13.	LC mounting configuration dimensions	32
Figure 14.	J6 jumper header	36
Figure 15.	J5 jumper header (on LW models only)	37
Figure 16.	J2 option select header (on LW models only)	38
Figure 17.	Air flow (suggested)	40
Figure 18.	LW model drive physical interface (68-pin J1 SCSI I/O connector)	56
Figure 19.	LC model drive physical interface (80-pin J1 SCSI I/O connector)	56
Figure 20.	SCSI daisy chain interface cabling for LW drives.	60
Figure 21.	Nonshielded 68 pin SCSI device connector used on LW drives	61
Figure 22.	Nonshielded 80 pin SCSI “SCA-2” connector, used on LC drives	62
Figure 23.	Typical SE-LVD alternative transmitter receiver circuits	68

1.0 Scope

This manual describes Seagate Technology® LLC, Cheetah® X15 36LP disc drives.

Cheetah X15 36LP drives support the small computer system interface (SCSI) as described in the ANSI SCSI SPI-4 interface specifications to the extent described in this manual. The *SCSI Interface Product Manual* (part number 75789509) describes general SCSI interface characteristics of this and other families of Seagate drives.

From this point on in this product manual the reference to Cheetah X15 36LP models is referred to as “the drive” unless references to individual models are necessary.

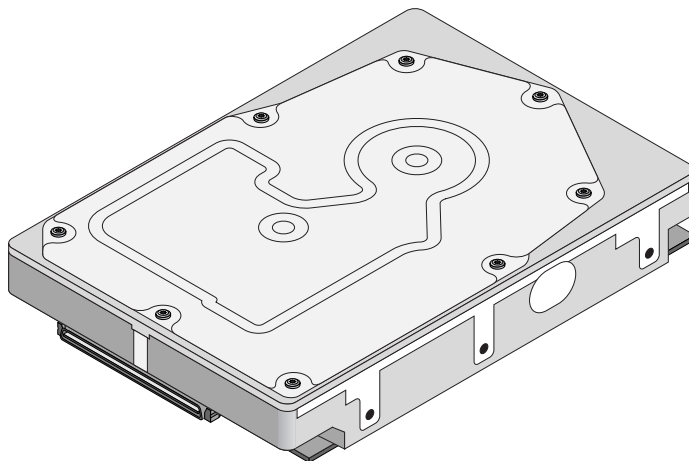

Figure 1. Cheetah X15 36LP family drive (ST336752LC shown)

2.0 Applicable standards and reference documentation

The drive has been developed as a system peripheral to the highest standards of design and construction. The drive depends upon its host equipment to provide adequate power and environment in order to achieve optimum performance and compliance with applicable industry and governmental regulations. Special attention must be given in the areas of safety, power distribution, shielding, audible noise control, and temperature regulation. In particular, the drive must be securely mounted in order to guarantee the specified performance characteristics. Mounting by bottom holes must meet the requirements of Section 8.4.

2.1 Standards

The Cheetah X15 36LP family complies with Seagate standards as noted in the appropriate sections of this Manual and the Seagate *SCSI Interface Product Manual*, part number 75789509 (Vol. 2).

The Cheetah X15 36LP disc drive is a UL recognized component per UL1950, CSA certified to CSA C22.2 No. 950-95, and VDE certified to VDE 0805 and EN60950.

2.1.1 Electromagnetic compatibility

The drive, as delivered, is designed for system integration and installation into a suitable enclosure prior to use. As such the drive is supplied as a subassembly and is not subject to Subpart B of Part 15 of the FCC Rules and Regulations nor the Radio Interference Regulations of the Canadian Department of Communications.

The design characteristics of the drive serve to minimize radiation when installed in an enclosure that provides reasonable shielding. As such, the drive is capable of meeting the Class B limits of the FCC Rules and Regulations of the Canadian Department of Communications when properly packaged. However, it is the user's responsibility to assure that the drive meets the appropriate EMI requirements in their system. Shielded I/O cables may be required if the enclosure does not provide adequate shielding. If the I/O cables are external to the enclosure, shielded cables should be used, with the shields grounded to the enclosure and to the host controller.

2.1.2 Electromagnetic susceptibility

As a component assembly, the drive is not required to meet any susceptibility performance requirements. It is the responsibility of those integrating the drive within their systems to perform those tests required and design their system to ensure that equipment operating in the same system as the drive or external to the system does not adversely affect the performance of the drive. See Section 5.1.1 and Table 3, DC power requirements.

2.2 Electromagnetic compliance

Seagate uses an independent laboratory to confirm compliance to the directives/standard(s) for CE Marking and C-Tick Marking. The drive was tested in a representative system for typical applications. The selected system represents the most popular characteristics for test platforms. The system configurations include:

- Typical current use microprocessor
- 3.5-inch floppy disc drive
- Keyboard
- Monitor/display
- Printer
- External modem
- Mouse

Although the test system with this Seagate model complies to the directives/standard(s), we cannot guarantee that all systems will comply. The computer manufacturer or system integrator shall confirm EMC compliance and provide CE Marking and C-Tick Marking for their product.

Electromagnetic compliance for the European Union

If this model has the CE Marking it complies with the European Union requirements of the Electromagnetic Compatibility Directive 89/336/EEC of 03 May 1989 as amended by Directive 92/31/EEC of 28 April 1992 and Directive 93/68/EEC of 22 July 1993.

Australian C-Tick

If this model has the C-Tick Marking it complies with the Australia/New Zealand Standard AS/NZS3548 1995 and meets the Electromagnetic Compatibility (EMC) Framework requirements of Australia's Spectrum Management Agency (SMA).

Korean MIC

If this model has the Korean Ministry of Information and Communication (MIC) logo, it complies with paragraph 1 of Article 11 of the Electromagnetic Compatibility (EMC) Control Regulation and meets the Electromagnetic Compatibility Framework requirements of the Radio Research Laboratory (RRL) Ministry of Information and Communication Republic of Korea.

Taiwanese BSMI

If this model has two Chinese words meaning "EMC certification" followed by an eight digit identification number, as a Marking, it complies with Chinese National Standard (CNS) 13438 and meets the Electromagnetic Compatibility (EMC) Framework requirements of the Taiwanese Bureau of Standards, Metrology, and Inspection (BSMI).

2.3 Reference documents

<i>Cheetah X15 36LP Installation Guide</i>	Seagate P/N 100139875
<i>Safety and Regulatory Agency Specifications</i>	Seagate P/N 75789512
<i>SCSI Interface Product Manual</i>	Seagate P/N 75789509

Applicable ANSI small computer system interface (SCSI) document numbers:

T10/1143D	Enhanced SCSI Parallel Interface (EPI)
T10/1416D	Primary Commands-3 (SPC-3)
T10/1417D	SCSI Block Commands (SBC-2)
T10/1157D	SCSI Architectural Model-2 (SAM-2)
T10/1365D	SCSI Parallel Interface - 4 (SPI-4)

SFF-8451, Specification for SCA-2 Unshielded Connections

Package Test Specification	Seagate P/N 30190-001 (under 100 lb.)
Package Test Specification	Seagate P/N 30191-001 (over 100 lb.)
Specification, Acoustic Test Requirements, and Procedures	Seagate P/N 30553-001

In case of conflict between this document and any referenced document, this document takes precedence.

3.0 General description

Cheetah X15 36LP drives combine giant magnetoresistive (GMR) heads, partial response/maximum likelihood (PRML) read channel electronics, embedded servo technology, and a wide Ultra160 SCSI interface (on ST336752 and ST318452 models) or a wide Ultra320 SCSI interface (on ST336732 and ST318432 models) to provide high performance, high capacity data storage for a variety of systems including engineering workstations, network servers, mainframes, and supercomputers.

Ultra160 and Ultra320 SCSI use negotiated transfer rates. These transfer rates will occur only if your host adapter supports these data transfer rates and is compatible with the required hardware requirements of the I/O circuit type. This drive also operates at SCSI-1 and SCSI-2 data transfer rates for backward compatibility with non-Ultra/Ultra2/Ultra160/Ultra320 SCSI host adapters.

Table 1 lists the features that differentiate the Cheetah X15 36LP models.

Table 1: Drive model number vs. differentiating features

Model number	Number of active heads	I/O circuit type [1]	Number of I/O connector pins	Interface	
				Ultra160	Ultra320
ST336752LW ST318452LW	8 4	Single-ended (SE) and low voltage differential (LVD)	68	X	
ST336752LC ST318452LC	8 4	Single-ended (SE) and low voltage differential (LVD)	80	X	
ST336732LW ST318432LW	8 4	Single-ended (SE) and low voltage differential (LVD)	68		X
ST336732LC ST318432LC	8 4	Single-ended (SE) and low voltage differential (LVD)	80		X

[1] See Section 9.6 for details and definitions.

The drive records and recovers data on approximately 2.5-inch (65 mm) non-removeable discs.

The drive supports the Small Computer System Interface (SCSI) as described in the ANSI SCSI interface specifications to the extent described in this manual (volume 1), which defines the product performance characteristics of the Cheetah X15 36LP family of drives, and the *SCSI Interface Product Manual* (volume 2), part number 75789509, which describes the general interface characteristics of this and other families of Seagate SCSI drives.

The drive's interface supports multiple initiators, disconnect/reconnect, self-configuring host software, and automatic features that relieve the host from the necessity of knowing the physical characteristics of the targets (logical block addressing is used).

The head and disc assembly (HDA) is sealed at the factory. Air circulates within the HDA through a non-replaceable filter to maintain a contamination-free HDA environment.

Never disassemble the HDA and do not attempt to service items in the sealed enclosure (heads, media, actuator, etc.) as this requires special facilities. The drive contains no replaceable parts. Opening the HDA voids your warranty.

Cheetah X15 36LP drives use a dedicated landing zone at the innermost radius of the media to eliminate the possibility of destroying or degrading data by landing in the data zone. The drive automatically goes to the landing zone when power is removed.

An automatic shipping lock prevents potential damage to the heads and discs that results from movement during shipping and handling. The shipping lock automatically disengages when power is applied to the drive and the head load process begins.

Cheetah X15 36LP drives decode track 0 location data from the servo data embedded on each surface to eliminate mechanical transducer adjustments and related reliability concerns.

A high-performance actuator assembly with a low-inertia, balanced, patented, straight-arm design provides excellent performance with minimal power dissipation.

3.1 Standard features

The Cheetah X15 36LP family has the following standard features:

- Multimode SCSI drivers and receivers—single-ended (SE) and low voltage differential (LVD)
- 16 bit I/O data bus
- Asynchronous and synchronous data transfer protocol
 - ST336752 and ST318452 models support Ultra160 transfer rates
 - ST336732 and ST318432 models support Ultra320 transfer rates
- Supports Information Unit transfer protocol
- Firmware downloadable via SCSI interface
- Selectable even byte sector sizes from 512 to 704 bytes/sector
- Programmable sector reallocation scheme
- Flawed sector reallocation at format time
- Programmable auto write and read reallocation
- Reallocation of defects on command (post format)
- ECC maximum burst correction length of 240 bits with a guaranteed burst correction length of 233 bits.
- Sealed head and disc assembly
- No preventative maintenance or adjustment required
- Dedicated head landing zone
- Embedded servo design
- Self diagnostics performed when power is applied to the drive
- Zoned bit recording (ZBR)
- Vertical, horizontal, or top down mounting
- Dynamic spindle brake
- 8,192 kbytes data buffer
- Hot plug compatibility (Section 9.6.4.2 lists proper host connector needed) for LC model drives
- Drive Self Test (DST)
- Supports SCSI bus fairness

3.2 Media characteristics

The media used on the drive has an aluminum substrate coated with a thin film magnetic material, overcoated with a proprietary protective layer for improved durability and environmental protection.

3.3 Performance

- Supports industry standard interfaces as follows:
 - ST336752 and ST318452 models support the Ultra160 SCSI interface
 - ST336732 and ST318432 models support the Ultra320 SCSI interface
- Programmable multi-segmentable cache buffer (see Section 4.5)
- 15k RPM spindle. Average latency = 2.0 ms
- Command queuing of up to 64 commands
- Background processing of queue
- Supports start and stop commands (spindle stops spinning)

3.4 Reliability

- 1,200,000 hour MTBF
- LSI circuitry
- Balanced low mass rotary voice coil actuator

- Incorporates industry-standard Self-Monitoring, Analysis and Reporting Technology (S.M.A.R.T.)
- 5-year warranty

3.5 Unformatted and formatted capacities

Formatted capacity depends on the number of spare reallocation sectors reserved and the number of bytes per sector. The following table shows the standard OEM model capacities:

	Formatted data block size 512 bytes/sector [1]	Unformatted
ST336752 and ST336732	445DCC9h (36.7 GB) [2]	47.5 GB
ST318452 and ST318432	222EE56h (18.4 GB) [2]	23.7 GB

Notes.

- [1] Sector size selectable at format time. Users having the necessary equipment may modify the data block size before issuing a format command and obtain different formatted capacities than those listed. See Mode Select Command and Format Command in the *SCSI Interface Product Manual*.
- [2] User available capacity depends on spare reallocation scheme selected, the number of data tracks per sparing zone, and the number of alternate sectors (LBAs) per sparing zone.

3.6 Programmable drive capacity

Using the Mode Select command, the drive can change its capacity to something less than maximum. See the Mode Select Parameter List table in the *SCSI Interface Product Manual*. Refer to the Parameter list block descriptor number of blocks field. A value of zero in the number of blocks field indicates that the drive shall not change the capacity it is currently formatted to have. A number in the number of blocks field that is less than the maximum number of LBAs changes the total drive capacity to the value in the block descriptor number of blocks field. A value greater than the maximum number of LBAs is rounded down to the maximum capacity.

3.7 Factory installed accessories

OEM Standard drives are shipped with the *Cheetah X15 36LP Installation Guide*, part number 100139875, and the *Safety and Regulatory Agency Specifications*, part number 75789512 (unless otherwise specified). The factory also ships with the drive a small bag of jumper plugs used for the J2, J5, and J6 option select jumper headers.

3.8 Options (factory installed)

All customer requested options are incorporated during production or packaged at the manufacturing facility before shipping. Some of the options available are (not an exhaustive list of possible options):

- Other capacities can be ordered depending on sparing scheme and sector size requested.
- Single unit shipping pack. The drive is normally shipped in bulk packaging to provide maximum protection against transit damage. Units shipped individually require additional protection as provided by the single unit shipping pack. Users planning single unit distribution should specify this option.
- The *Cheetah X15 36LP Installation Guide*, part number 100139875, is usually included with each standard OEM drive shipped, but extra copies may be ordered.
- The *Safety and Regulatory Agency Specifications*, part number 75789512, is usually included with each standard OEM drive shipped, but extra copies may be ordered.

3.9 Accessories (user installed)

The following accessories are available. All accessories may be installed in the field.

- Single unit shipping pack.

4.0 Performance characteristics

4.1 Internal drive characteristics (transparent to user)

	ST336752 and ST336732	ST318452 and ST318432	
Drive capacity	36.7	18.4	GByte (formatted, rounded off values)
Read/write heads	8	4	
Bytes/track	316,155	316,155	Bytes (average, rounded off values)
Bytes/surface	5,932.5	5,932.5	Mbytes (unformatted, rounded off values)
Tracks/surface (total)	18,497	18,497	Tracks (user accessible)
Tracks/inch	38,000	38,000	TPI
Peak bits/inch	482	482	KBPI
Internal data rate	548-706	548-706	Mbits/sec (variable with zone)
Disc rotational speed	15k	15k	r/min
Average rotational latency	2.0	2.0	msec

4.2 SCSI performance characteristics (visible to user)

The values given in Section 4.2.1 apply to all models of the Cheetah X15 36LP family unless otherwise specified. Refer to Section 9.10 and to the *SCSI Interface Product Manual* for additional timing details.

4.2.1 Access time [5]

				Including controller overhead (without disconnect) [1] [3]		Not including controller overhead (without disconnect) [1] [3]	
				Drive level		Drive level	
				Read	Write	Read	Write
				msec		msec	
Average	–	Typical	[2]	3.8	4.4	3.6	4.2
Single Track	–	Typical	[2]	0.5	0.6	0.3	0.4
Full Stroke	–	Typical	[2]	7.2	8.2	7.0	8.0

4.2.2 Format command execution time (minutes) [1]

	ST336752 and ST336732	ST318452 and ST318432
Maximum (with verify)	90	60
Maximum (no verify)	45	30

4.2.3 Generalized performance characteristics

Minimum sector interleave 1 to 1

Data buffer transfer rate to/from disc media (one 512-byte sector):

Min. [3]*	51.8	MBytes/sec
Max. [3]	68.1	MBytes/sec

SCSI interface data transfer rate (asynchronous):

Maximum instantaneous one byte wide	5.0 Mbytes/sec [4]
Maximum instantaneous two bytes wide	10.0 Mbytes/sec [4]

Synchronous formatted transfer rate

In low voltage differential (LVD) interface mode	Ultra160 SCSI 5.0 to 160 Mbytes/sec	Ultra320 SCSI 5.0 to 320 Mbytes/sec
--	---	---

Sector Sizes:

Default	512 byte user data blocks
Variable	512 to 704 bytes per sector in even number of bytes per sector. If n (number of bytes per sector) is odd, then n-1 will be used.

Read/write consecutive sectors on a track	Yes
Flaw reallocation performance impact (for flaws reallocated at format time using the spare sectors per sparing zone reallocation scheme.)	Negligible
Average rotational latency	2.00 msec

Notes for Section 4.2.

- [1] Execution time measured from receipt of the last byte of the Command Descriptor Block (CDB) to the request for a Status Byte Transfer to the Initiator (excluding connect/disconnect).
- [2] Typical access times are measured under nominal conditions of temperature, voltage, and horizontal orientation as measured on a representative sample of drives.
- [3] Assumes no errors and no sector has been relocated.
- [4] Assumes system ability to support the rates listed and no cable loss.
- [5] Access time = controller overhead + average seek time.
Access to data = controller overhead + average seek time + latency time.

4.3 Start/stop time

After DC power at nominal voltage has been applied, the drive becomes ready within 20 seconds if the Motor Start Option is disabled (i.e. the motor starts as soon as the power has been applied). If a recoverable error condition is detected during the start sequence, the drive executes a recovery procedure which may cause the time to become ready to exceed 20 seconds. During spin up to ready time the drive responds to some commands over the SCSI interface in less than 3 seconds after application of power. Stop time is 30 seconds from removal of DC power.

If the Motor Start Option is enabled, the internal controller accepts the commands listed in the SCSI Interface Product Manual less than 3 seconds after DC power has been applied. After the Motor Start Command has been received the drive becomes ready for normal operations within 20 seconds typically (excluding an error recovery procedure). The Motor Start Command can also be used to command the drive to stop the spindle (see the *SCSI Interface Product Manual*).

There is no power control switch on the drive.

4.4 Prefetch/multi-segmented cache control

The drive provides prefetch (read look-ahead) and multi-segmented cache control algorithms that in many cases can enhance system performance. "Cache" as used herein refers to the drive buffer storage space when it is used in cache operations. To select prefetch and cache features the host sends the Mode Select command with the proper values in the applicable bytes in Mode Page 08h (see the *SCSI Interface Product Manual*). Prefetch and cache operation are independent features from the standpoint that each is enabled and disabled independently via the Mode Select command. However, in actual operation the prefetch feature overlaps cache operation somewhat as is noted in Section 4.5.1 and 4.5.2.

All default cache and prefetch Mode parameter values (Mode Page 08h) for standard OEM versions of this drive family are given in Tables 8.

4.5 Cache operation

In general, 7,500 kbytes of the physical buffer space in the drive can be used as storage space for cache operations. The buffer can be divided into logical segments (Mode Select Page 08h, byte 13) from which data is read and to which data is written. The drive supports a maximum of 64 cache segments. The drive maintains a table of logical block disk medium addresses of the data stored in each segment of the buffer. If cache operation is enabled (RCD bit = 0 in Mode Page 08h, byte 2, bit 0. See *SCSI Interface Product Manual*), data

requested by the host with a Read command is retrieved from the buffer (if it is there), before any disc access is initiated. If cache operation is not enabled, the buffer (still segmented with required number of segments) is still used, but only as circular buffer segments during disc medium read operations (disregarding Prefetch operation for the moment). That is, the drive does not check in the buffer segments for the requested read data, but goes directly to the medium to retrieve it. The retrieved data merely passes through some buffer segment on the way to the host. On a cache miss, all data transfers to the host are in accordance with buffer-full ratio rules. On a cache hit the drive ignores the buffer-full ratio rules. See explanations associated with Mode page 02h (disconnect/reconnect control) in the *SCSI Interface Product Manual*.

The following is a simplified description of a read operation with cache operation enabled:

Case A - A Read command is received and the first logical block (LB) is already in cache:

1. Drive transfers to the initiator the first LB requested plus all subsequent contiguous LBs that are already in the cache. This data may be in multiple segments.
2. When the requested LB is reached that is not in any cache segment, the drive fetches it and any remaining requested LBs from the disc and puts them in a segment of the cache. The drive transfers the remaining requested LBs from the cache to the host in accordance with the disconnect/reconnect specification mentioned above.
3. If the prefetch feature is enabled, refer to Section 4.5.2 for operation from this point.

Case B - A Read command requests data, the first LB of which is not in any segment of the cache:

1. The drive fetches the requested LBs from the disc and transfers them into a segment, and from there to the host in accordance with the disconnect/reconnect specification referred to in case A.
2. If the prefetch feature is enabled, refer to Section 4.5.2 for operation from this point.

Each buffer segment is actually a self-contained circular storage (wrap-around occurs), the length of which is an integer number of disc medium sectors. The wrap-around capability of the individual segments greatly enhances the buffer's overall performance as a cache storage, allowing a wide range of user selectable configurations, which includes their use in the prefetch operation (if enabled), even when cache operation is disabled (see Section 4.5.2). The number of segments is set dynamically by the drive and cannot be set by the host. The size in Kbytes of each segment is not reported by the Mode Sense command page 08h, bytes 14 and 15. The value 0XFFFF is always reported. If a size specification is sent by the host in a Mode Select command (bytes 14 and 15) no new segment size is set up by the drive, and if the STRICT bit in Mode page 00h (byte 2, bit 1) is set to one, the drive responds as it does for any attempt to change unchangeable parameters (see *SCSI Interface Product Manual*).

4.5.1 Caching write data

Write caching is a write operation by the drive that makes use of a drive buffer storage area where the data to be written to the medium is stored in one or more segments while the drive performs the write command.

If read caching is enabled (RCD=0), then data written to the medium is retained in the cache to be made available for future read cache hits. The same buffer space and segmentation is used as set up for read functions. The buffer segmentation scheme is set up or changed independently, having nothing to do with the state of RCD. When a write command is issued, if RCD=0, the cache is first checked to see if any logical blocks that are to be written are already stored in the cache from a previous read or write command. If there are, the respective cache segments are cleared. The new data is cached for subsequent Read commands.

If the number of write data logical blocks exceeds the size of the segment being written into, when the end of the segment is reached, the data is written into the beginning of the same cache segment, overwriting the data that was written there at the beginning of the operation. However, the drive does not overwrite data that has not yet been written to the medium.

If write caching is enabled (WCE=1), then the drive may return GOOD status on a write command after the data has been transferred into the cache, but before the data has been written to the medium. If an error occurs while writing the data to the medium, and GOOD status has already been returned, a deferred error will be generated.

The Synchronize Cache command may be used to force the drive to write all cached write data to the medium. Upon completion of a Synchronize Cache command, all data received from previous write commands will have been written to the medium.

Tables 8 show Mode default settings for the drives.

4.5.2 Prefetch operation

If the Prefetch feature is enabled, data in contiguous logical blocks on the disc immediately beyond that which was requested by a Read command can be retrieved and stored in the buffer for immediate transfer from the buffer to the host on subsequent Read commands that request those logical blocks (this is true even if cache operation is disabled). Though the prefetch operation uses the buffer as a cache, finding the requested data in the buffer is a prefetch hit, not a cache operation hit. Prefetch is enabled using Mode Select page 08h, byte 12, bit 5 (Disable Read Ahead - DRA bit). DRA bit = 0 enables prefetch. Since data that is prefetched replaces data already in some buffer segment(s), the host can limit the amount of prefetch data to optimize system performance. The max prefetch field (bytes 8 and 9) limits the amount of prefetch. The drive does not use the Prefetch Ceiling field (bytes 10 and 11).

During a prefetch operation, the drive crosses a cylinder boundary to fetch more data only if the Discontinuity (DISC) bit is set to one in bit 4 of byte 2 of Mode parameters page 08h.

Whenever prefetch (read look-ahead) is enabled (enabled by DRA = 0), it operates under the control of ARLA (Adaptive Read Look-Ahead). If the host uses software interleave, ARLA enables prefetch of contiguous blocks from the disc when it senses that a prefetch hit will likely occur, even if two consecutive read operations were not for physically contiguous blocks of data (e.g., “software interleave”). ARLA disables prefetch when it decides that a prefetch hit will not likely occur. If the host is not using software interleave, and if two sequential read operations are not for contiguous blocks of data, ARLA disables prefetch, but as long as sequential read operations request contiguous blocks of data, ARLA keeps prefetch enabled.

4.5.3 Optimizing cache performance for desktop and server applications

Desktop and server applications require different drive caching operations for optimal performance. This means it is difficult to provide a single configuration that meets both of these needs. In a desktop environment, you want to configure the cache to respond quickly to repetitive accesses of multiple small segments of data without taking the time to “look ahead” to the next contiguous segments of data. In a server environment, you want to configure the cache to provide large volumes of sequential data in a non-repetitive manner. In this case, the ability of the cache to “look ahead” to the next contiguous segments of sequential data is a good thing.

The Performance Mode (PM) bit controls the way the drive switches the cache buffer into different modes of segmentation. In “server mode” (PM bit = 0), the drive can dynamically change the number of cache buffer segments as needed to optimize the performance, based on the command stream from the host. In “desktop mode” (PM bit = 1), the number of segments is maintained at the value defined in Mode Page 8, Byte 13, at all times (unless changed by using a Mode Select command). For additional information about the PM bit, refer to the Unit Attention Parameters page (00h) of the Mode Sense command (1Ah) in the *SCSI Interface Product Manual*, part number 75789509.

5.0 Reliability specifications

The following reliability specifications assume correct host/drive operational interface, including all interface timings, power supply voltages, environmental requirements and drive mounting constraints (see Section 8.4).

Seek Errors	Less than 10 in 10^8 seeks
Read Error Rates [1]	
Recovered Data	Less than 10 errors in 10^{12} bits transferred (OEM default settings)
Unrecovered Data	Less than 1 sector in 10^{15} bits transferred (OEM default settings)
Miscorrected Data	Less than 1 sector in 10^{21} bits transferred
MTBF	1,200,000 hours
Service Life	5 years
Preventive Maintenance	None required

Note.

[1] Error rate specified with automatic retries and data correction with ECC enabled and all flaws reallocated.

5.1 Error rates

The error rates stated in this specification assume the following:

- The drive is operated per this specification using DC power as defined in this manual (see Section 6.2).
- The drive has been formatted with the SCSI FORMAT command.
- Errors caused by media defects or host system failures are excluded from error rate computations. Refer to Section 3.2, "Media Characteristics."
- Assume random data.

5.1.1 Environmental interference

When evaluating systems operation under conditions of Electromagnetic Interference (EMI), the performance of the drive within the system shall be considered acceptable if the drive does not generate an unrecoverable condition.

An unrecoverable error, or unrecoverable condition, is defined as one that:

- Is not detected and corrected by the drive itself;
- Is not capable of being detected from the error or fault status provided through the drive or SCSI interface; or
- Is not capable of being recovered by normal drive or system recovery procedures without operator intervention.

5.1.2 Read errors

Before determination or measurement of read error rates:

- The data that is to be used for measurement of read error rates must be verified as being written correctly on the media.
- All media defect induced errors must be excluded from error rate calculations.

5.1.3 Write errors

Write errors can occur as a result of media defects, environmental interference, or equipment malfunction. Therefore, write errors are not predictable as a function of the number of bits passed.

If an unrecoverable write error occurs because of an equipment malfunction in the drive, the error is classified as a failure affecting MTBF. Unrecoverable write errors are those which cannot be corrected within two attempts at writing the record with a read verify after each attempt (excluding media defects).

5.1.4 Seek errors

A seek error is defined as a failure of the drive to position the heads to the addressed track. There shall be no more than ten recoverable seek errors in 10^8 physical seek operations. After detecting an initial seek error, the drive automatically performs an error recovery process. If the error recovery process fails, a seek positioning

error (15h) is reported with a Medium error (3h) or Hardware error (4h) reported in the Sense Key. This is an unrecoverable seek error. Unrecoverable seek errors are classified as failures for MTBF calculations. Refer to the *SCSI Interface Product Manual*, part number 75789509, for Request Sense information.

5.2 Reliability and service

You can enhance the reliability of Cheetah X15 36LP disc drives by ensuring that the drive receives adequate cooling. Section 6.0 provides temperature measurements and other information that may be used to enhance the service life of the drive. Section 8.3 provides recommended air-flow information.

5.2.1 Mean time between failure

The production disc drive shall achieve an MTBF of 1,200,000 hours when operated in an environment that ensures the HDA case temperatures specified in Section 6.4 are not exceeded. Short-term excursions up to the specification limits of the operating environment will not affect MTBF performance. Continual or sustained operation at case temperatures above the values shown in Section 6.4.1 may degrade product reliability.

The MTBF target is specified as device power-on hours (POH) for all drives in service per failure.

$$\text{Estimated power-on operating hours in the period} = \frac{\text{MTBF per measurement period}}{\text{Number of drive failures in the period}}$$

Estimated power-on operation hours means power-up hours per disc drive times the total number of disc drives in service. Each disc drive shall have accumulated at least nine months of operation. Data shall be calculated on a rolling average base for a minimum period of six months.

MTBF is based on the following assumptions:

- 8,760 power-on hours per year.
- 250 average on/off cycles per year.
- Operations at nominal voltages.
- Systems will provide adequate cooling to ensure the case temperatures specified in Section 6.4.1 are not exceeded.

Drive failure means any stoppage or substandard performance caused by drive malfunction.

A S.M.A.R.T. predictive failure indicates that the drive is deteriorating to an imminent failure and is considered an MTBF hit.

5.2.2 Preventive maintenance

No routine scheduled preventive maintenance shall be required.

5.2.3 Service life

The drive shall have a useful service life of five years. Depot repair or replacement of major parts is permitted during the lifetime (see Section 5.2.4).

5.2.4 Service philosophy

Special equipment is required to repair the drive HDA. In order to achieve the above service life, repairs must be performed only at a properly equipped and staffed service and repair facility. Troubleshooting and repair of PCBs in the field is not recommended, because of the extensive diagnostic equipment required for effective servicing. Also, there are no spare parts available for this drive. Drive warranty is voided if the HDA is opened.

5.2.5 Service tools

No special tools are required for site installation or recommended for site maintenance. Refer to Section 5.2.4. The depot repair philosophy of the drive precludes the necessity for special tools. Field repair of the drive is not practical since there are no user purchasable parts in the drive.

5.2.6 Hot plugging Cheetah X15 36LP disc drives

The SPI-4 standard defines the physical requirements for removal and insertion of SCSI devices on the SCSI bus. Four cases are addressed. The cases are differentiated by the state of the SCSI bus when the removal or insertion occurs.

Case 1 - All bus devices powered off during removal or insertion

Case 2 - RST signal asserted continuously during removal or insertion

Case 3 - Current I/O processes not allowed during insertion or removal

Case 4 - Current I/O process allowed during insertion or removal, except on the device being changed

Seagate Cheetah X15 36LP disc drives support all four hot plugging cases. Provision shall be made by the system such that a device being inserted makes power and ground connections prior to the connection of any device signal contact to the bus. A device being removed shall maintain power and ground connections after the disconnection of any device signal contact from the bus (see SFF-8451, SCA-2 Unshielded Connections).

It is the responsibility of the systems integrator to assure that no hazards from temperature, energy, voltage, or ESD potential are presented during the hot connect/disconnect operation.

All I/O processes for the SCSI device being inserted or removed shall be quiescent. All SCSI devices on the bus shall have receivers that conform to the SPI-4 standard.

If the device being hot plugged uses single-ended (SE) drivers and the bus is currently operating in low voltage differential (LVD) mode, then all I/O processes for all devices on the bus must be completed, and the bus quiesced, before attempting to hot plug. Following the insertion of the newly installed device, the SCSI host adapter must issue a Bus Reset, followed by a synchronous transfer negotiation. Failure to perform the SCSI Bus Reset could result in erroneous bus operations.

The SCSI bus termination and termination power source shall be external to the device being inserted or removed.

End users should not mix devices with high voltage differential (HVD) drivers and receivers and devices with SE, LVD, or multimode drivers and receivers on the same SCSI bus since the common mode voltages in the HVD environment may not be controlled to safe levels for SE and LVD devices (see the SPI-4 standard).

The disc drive spindle must come to a complete stop prior to completely removing the drive from the cabinet chassis. Use of the Stop Spindle command or partial withdrawal of the drive, enough to be disconnected from the power source, prior to removal are methods for insuring that this requirement is met. During drive insertion, care should be taken to avoid exceeding the limits stated in Section 6.4.4, "Shock and vibration" in this manual.

5.2.7 S.M.A.R.T.

S.M.A.R.T. is an acronym for Self-Monitoring Analysis and Reporting Technology. This technology is intended to recognize conditions that indicate a drive failure and is designed to provide sufficient warning of a failure to allow data back-up before an actual failure occurs.

Note. The firmware will monitor specific attributes for degradation over time but cannot predict instantaneous drive failures.

Each attribute has been selected to monitor a specific set of failure conditions in the operating performance of the drive, and the thresholds are optimized to minimize "false" and "failed" predictions.

Controlling S.M.A.R.T.

The operating mode of S.M.A.R.T. is controlled by the DEXCPT bit and the PERF bit of the "Informational Exceptions Control Mode Page" (1Ch). The DEXCPT bit is used to enable or disable the S.M.A.R.T. process. Setting the DEXCPT bit will disable all S.M.A.R.T. functions. When enabled, S.M.A.R.T. will collect on-line data as the drive performs normal read/write operations. When the PERF bit is set, the drive is considered to be in "On-line Mode Only" and will not perform off-line functions.

The process of measuring off-line attributes and saving data can be forced by the Rezero Unit command. Forcing S.M.A.R.T. will reset the timer so that the next scheduled interrupt will be two hours.

The drive can be interrogated by the host to determine the time remaining before the next scheduled measurement and data logging process will occur. This is accomplished by a log sense command to log page 0x3E. The purpose is to allow the customer to control when S.M.A.R.T. interruptions occur. As described above, forcing S.M.A.R.T. by the Rezero Unit command will reset the timer.

Performance impact

S.M.A.R.T. attribute data will be saved to the disc for the purpose of recreating the events that caused a predictive failure. The drive will measure and save parameters once every two hours subject to an idle period on the SCSI bus. The process of measuring off-line attribute data and saving data to the disc is uninterruptable and the maximum delay is summarized below:

Maximum processing delay

On-line only delay Fully enabled delay

DEXCPT = 0, PERF = 1 DEXCPT = 0, PERF = 0

S.M.A.R.T. delay times 50 milliseconds 300 milliseconds

Reporting control

Reporting is controlled in the Informational Exceptions Control Page (1Ch). Subject to the reporting method, the firmware will issue a 01-5D00 sense code to the host. The error code is preserved through bus resets and power cycles.

Determining rate

S.M.A.R.T. monitors the rate at which errors occur and signals a predictive failure if the rate of degraded error rate increases to an unacceptable level. To determine rate, error events are logged and compared to the number of total operations for a given attribute. The interval defines the number of operations over which to measure the rate. The counter that keeps track of the current number of operations is referred to as the Interval Counter.

S.M.A.R.T. measures error rate, hence for each attribute the occurrence of an error is recorded. A counter keeps track of the number of errors for the current interval. This counter is referred to as the Failure Counter.

Error rate is simply the number of errors per operation. The algorithm that S.M.A.R.T. uses to record rates of error is to set thresholds for the number of errors and the interval. If the number of errors exceeds the threshold before the interval expires, then the error rate is considered to be unacceptable. If the number of errors does not exceed the threshold before the interval expires, then the error rate is considered to be acceptable. In either case, the interval and failure counters are reset and the process starts over.

Predictive failures

S.M.A.R.T. signals predictive failures when the drive is performing unacceptably for a period of time. The firmware keeps a running count of the number of times the error rate for each attribute is unacceptable. To accomplish this, a counter is incremented whenever the error rate is unacceptable and decremented (not to exceed zero) whenever the error rate is acceptable. Should the counter continually be incremented such that it reaches the predictive threshold, a predictive failure is signaled. This counter is referred to as the Failure History Counter. There is a separate Failure History Counter for each attribute.

5.2.8 Thermal Monitor

Cheetah X15 36LP drives implement a temperature warning system which:

1. Signals the host if the temperature exceeds a value which would threaten the drive.
2. Signals the host if the temperature exceeds a user-specified value.
3. Saves a S.M.A.R.T. data frame on the drive which exceed the threatening temperature value.

A temperature sensor monitors the drive temperature and issues a warning over the interface when the temperature exceeds a set threshold. The temperature is measured at power-up and then at ten-minute intervals after power-up.

The thermal monitor system generates a warning code of 01-0B01 when the temperature exceeds the specified limit in compliance with the SCSI standard. The drive temperature is reported in the FRU code field of mode sense data. You can use this information to determine if the warning is due to the temperature exceeding the drive threatening temperature or the user-specified temperature.

This feature is controlled by the Enable Warning (EWasc) bit, and the reporting mechanism is controlled by the Method of Reporting Informational Exceptions field (MRIE) on the Informational Exceptions Control (IEC) mode page (1Ch).

The current algorithm implements two temperature trip points. The first trip point is set at 65°C which is the maximum temperature limit according to the drive specification. The second trip point is user-selectable using the Log Select command. The reference temperature parameter in the temperature log page (see Table 2) can be used to set this trip point. The default value for this drive is 65°C, however, you can set it to any value in the range of 0 to 65°C. If you specify a temperature greater than 65°C in this field, the temperature is rounded down to 65°C. A sense code is sent to the host to indicate the rounding of the parameter field.

Table 2: Temperature Log page (0Dh)

Parameter Code	Description
0000h	Primary Temperature
0001h	Reference Temperature

When the first temperature trip point is exceeded, S.M.A.R.T. data is collected and a frame is saved to the disc.

5.2.9 Drive Self Test (DST)

Drive Self Test (DST) is a technology designed to recognize drive fault conditions that qualify the drive as a failed unit. DST validates the functionality of the drive at a system level.

There are two test coverage options implemented in DST:

1. Extended test
2. Short test

The most thorough option is the extended test that performs various tests on the drive and scans every logical block address (LBA) of the drive. The short test is time-restricted and limited in length—it does not scan the entire media surface, but does some fundamental tests and scans portions of the media.

If DST encounters an error during either of these tests, it reports a fault condition. If the drive fails the test, remove it from service and return it to Seagate for service.

5.2.9.1 DST Failure Definition

The drive will present a “diagnostic failed” condition through the self-tests results value of the diagnostic log page if a functional failure is encountered during DST. The channel and servo parameters are not modified to test the drive more stringently, and the number of retries are not reduced. All retries and recovery processes are enabled during the test. If data is recoverable, no failure condition will be reported regardless of the number of retries required to recover the data.

The following conditions are considered DST failure conditions:

- Seek error after retries are exhausted
- Track-follow error after retries are exhausted
- Read error after retries are exhausted
- Write error after retries are exhausted

Recovered errors will not be reported as diagnostic failures.

5.2.9.2 Implementation

This section provides all of the information necessary to implement the DST function on this drive.

5.2.9.2.1 State of the drive prior to testing

The drive must be in a ready state before issuing the Send Diagnostic command. There are multiple reasons why a drive may not be ready, some of which are valid conditions, and not errors. For example, a drive may be in process of doing a format, or another DST. It is the responsibility of the host application to determine the “not ready” cause.

While not technically part of DST, a Not Ready condition also qualifies the drive to be returned to Seagate as a failed drive.

A Drive Not Ready condition is reported by the drive under the following conditions:

- Motor will not spin
- Motor will not lock to speed
- Servo will not lock on track
- Drive cannot read configuration tables from the disc

In these conditions, the drive responds to a Test Unit Ready command with an 02/04/00 or 02/04/03 code.

5.2.9.2.2 Invoking DST

To invoke DST, submit the Send Diagnostic command with the appropriate Function Code (001b for the short test or 010b for the extended test) in bytes 1, bits 5, 6, and 7. Refer to the Seagate SCSI Interface Manual, part number 75789509, for additional information about invoking DST.

5.2.9.2.3 Short and extended tests

DST has two testing options:

1. short
2. extended

These testing options are described in the following two subsections.

Each test consists of three segments: an electrical test segment, a servo test segment, and a read/verify scan segment.

Short test (Function Code: 001b)

The purpose of the short test is to provide a time-limited test that tests as much of the drive as possible within 120 seconds. The short test does not scan the entire media surface, but does some fundamental tests and scans portions of the media. A complete read/verify scan is not performed and only factual failures will report a fault condition. This option provides a quick confidence test of the drive.

Extended test (Function Code: 010b)

The objective of the extended test option is to empirically test critical drive components. For example, the seek tests and on-track operations test the positioning mechanism. The read operation tests the read head element and the media surface. The write element is tested through read/write/read operations. The integrity of the media is checked through a read/verify scan of the media. Motor functionality is tested by default as a part of these tests.

The anticipated length of the Extended test is reported through the Control Mode page.

5.2.9.2.4 Log page entries

When the drive begins DST, it creates a new entry in the Self-test Results Log page. The new entry is created by inserting a new self-test parameter block at the beginning of the self-test results log parameter section of the log page. Existing data will be moved to make room for the new parameter block. The drive reports 20

parameter blocks in the log page. If there are more than 20 parameter blocks, the least recent parameter block will be deleted. The new parameter block will be initialized as follows:

1. The Function Code field is set to the same value as sent in the DST command
2. The Self-Test Results Value field is set to Fh
3. The drive will store the log page to non-volatile memory

After a self-test is complete or has been aborted, the drive updates the Self-Test Results Value field in its Self-Test Results Log page in non-volatile memory. The host may use Log Sense to read the results from up to the last 20 self-tests performed by the drive. The self-test results value is a 4-bit field that reports the results of the test. If the field is zero, the drive passed with no errors detected by the DST. If the field is not zero, the test failed for the reason reported in the field.

The drive will report the failure condition and LBA (if applicable) in the Self-test Results Log parameter. The Sense key, ASC, ASCQ, and FRU are used to report the failure condition.

5.2.9.2.5 Abort

There are several ways to abort a diagnostic. You can use a SCSI Bus Reset or a Bus Device Reset message to abort the diagnostic.

You can abort a DST executing in background mode by using the abort code in the DST Function Code field. This will cause a 01 (self-test aborted by the application client) code to appear in the self-test results values log. All other abort mechanisms will be reported as a 02 (self-test routine was interrupted by a reset condition).

5.2.10 Product warranty

Beginning on the date of shipment to customer and continuing for a period of five years, Seagate warrants that each product (including components and subassemblies) or spare part that fails to function properly under normal use due to defect in materials or workmanship or due to nonconformance to the applicable specifications will be repaired or replaced, at Seagate's option and at no charge to customer, if returned by customer at customer's expense to Seagate's designated facility in accordance with Seagate's warranty procedure. Seagate will pay for transporting the repair or replacement item to customer. For more detailed warranty information refer to the Standard terms and conditions of Purchase for Seagate products.

Shipping

When transporting or shipping a drive, a Seagate approved container must be used. Keep your original box. They are easily identified by the Seagate-approved package label. Shipping a drive in a non-approved container voids the drive warranty.

Seagate repair centers may refuse receipt of components improperly packaged or obviously damaged in transit. Contact your Authorized Seagate Distributor to purchase additional boxes. Seagate recommends shipping by an air-ride carrier experienced in handling computer equipment.

Product repair and return information

Seagate customer service centers are the only facilities authorized to service Seagate drives. Seagate does not sanction any third-party repair facilities. Any unauthorized repair or tampering with the factory-seal voids the warranty.

6.0 Physical/electrical specifications

This section provides information relating to the physical and electrical characteristics of the Cheetah X15 36LP drive.

6.1 AC power requirements

None.

6.2 DC power requirements

The voltage and current requirements for a single drive are shown in the following table. Values indicated apply at the drive power connector. The table shows current values in Amperes.

Table 3: DC power requirements

	Notes	ST336752 and ST336732				ST318452 and ST318432			
		SE mode		LVD mode		SE mode		LVD mode	
Voltage		+5 V	+12 V	+5 V	+12 V	+5 V	+12 V	+5 V	+12 V
Regulation	[5]	±5%	±5% [2]	±5%	±5% [2]	±5%	±5% [2]	±5%	±5% [2]
Average idle current DC	\bar{X} [1][7]	0.78	0.68	0.83	0.68	0.78	0.51	0.83	0.51
Maximum starting current (peak DC) DC	3σ [3]	0.83	1.73	0.92	1.73	0.87	1.44	0.90	1.44
(peak AC) AC	3σ [3]	1.16	3.33	1.22	3.33	1.21	2.51	1.18	2.51
Delayed motor start (max) DC	3σ [1][4]	0.68	0.03	0.73	0.03	0.69	0.03	0.74	0.03
Peak operating current DC	\bar{X} [1][6]	0.81	0.98	0.89	0.98	0.79	0.79	0.88	0.79
Maximum DC	3σ [1]	0.85	1.23	0.93	1.23	0.84	0.99	0.93	0.99
Maximum (peak) DC	3σ	1.25	2.25	1.55	2.25	1.18	2.32	1.44	2.32

- [1] Measured with average reading DC ammeter or equivalent sampling scope. Instantaneous current peaks will exceed these values. Power supply at nominal voltage. N (number of drives tested) = 6, 35 Degrees C ambient.
- [2] For +12 V, a –10% tolerance is permissible during initial start of spindle, and must return to ±5% before 15,000 rpm is reached. The ±5% must be maintained after the drive signifies that its power-up sequence has been completed and that the drive is able to accept selection by the host initiator.
- [3] See +12 V current profile in Figure 2.
- [4] This condition occurs when the Motor Start Option is enabled and the drive has not yet received a Start Motor command.
- [5] See Section 6.2.1 “Conducted Noise Immunity.” Specified voltage tolerance is inclusive of ripple, noise, and transient response.
- [6] Operating condition is defined as random 8 block reads at 282 I/Os per second (284 I/Os per second for ST318452 models). Current and power specified at nominal voltages. Decreasing +5 volts by 5% increases 5 volt current by 3.2%. Decreasing +12 volt supply by 5% increases 12 volt current by 1.4% (2% for ST318452 models).
- [7] During idle, the drive heads are relocated every 60 seconds to a random location within the band from three-quarters to maximum track.

General Notes from Table 3:

- Minimum current loading for each supply voltage is not less than 1.7% of the maximum operating current shown.
- The +5 and +12 volt supplies shall employ separate ground returns.
- Where power is provided to multiple drives from a common supply, careful consideration for individual drive power requirements should be noted. Where multiple units are powered on simultaneously, the peak starting current must be available to each device.
- Parameters, other than spindle start, are measured after a 10-minute warm up.
- No terminator power.

6.2.1 Conducted noise immunity

Noise is specified as a periodic and random distribution of frequencies covering a band from DC to 10 MHz. Maximum allowed noise values given below are peak to peak measurements and apply at the drive power connector.

- +5 V = 150 mV pp from 0 to 100 kHz and 100 mV pp from 100 kHz to 10 MHz.
- +12 V = 150 mV pp from 0 to 100 kHz and 100 mV pp from 100 kHz to 10 MHz.

6.2.2 Power sequencing

The drive does not require power sequencing. The drive protects against inadvertent writing during power-up and down. Daisy-chain operation requires that power be maintained on the SCSI bus terminator to ensure proper termination of the peripheral I/O cables. To automatically delay motor start based on the target ID (SCSI ID) enable the Delay Motor Start option and disable the Enable Motor Start option on the J2 connector. See Section 8.1 for pin selection information. To delay the motor until the drive receives a Start Unit command, enable the Enable Remote Motor Start option on the J2 connector.

6.2.3 12 V - Current profile

Figure 2 identifies the drive +12 V current profile. The current during the various times is as shown:

- T0 - Power is applied to the drive.
- T1 - Controller self tests are performed.
- T2 - Spindle begins to accelerate under current limiting after performing drive internal diagnostics. See Note 1 of Table 2.
- T3 - The spindle is up to speed and the head-arm restraint is unlocked.
- T4 - The adaptive servo calibration sequence is performed.
- T5 - Calibration is complete and drive is ready for reading and writing.

Note. All times and currents are typical. See Table 3 for maximum current requirements.

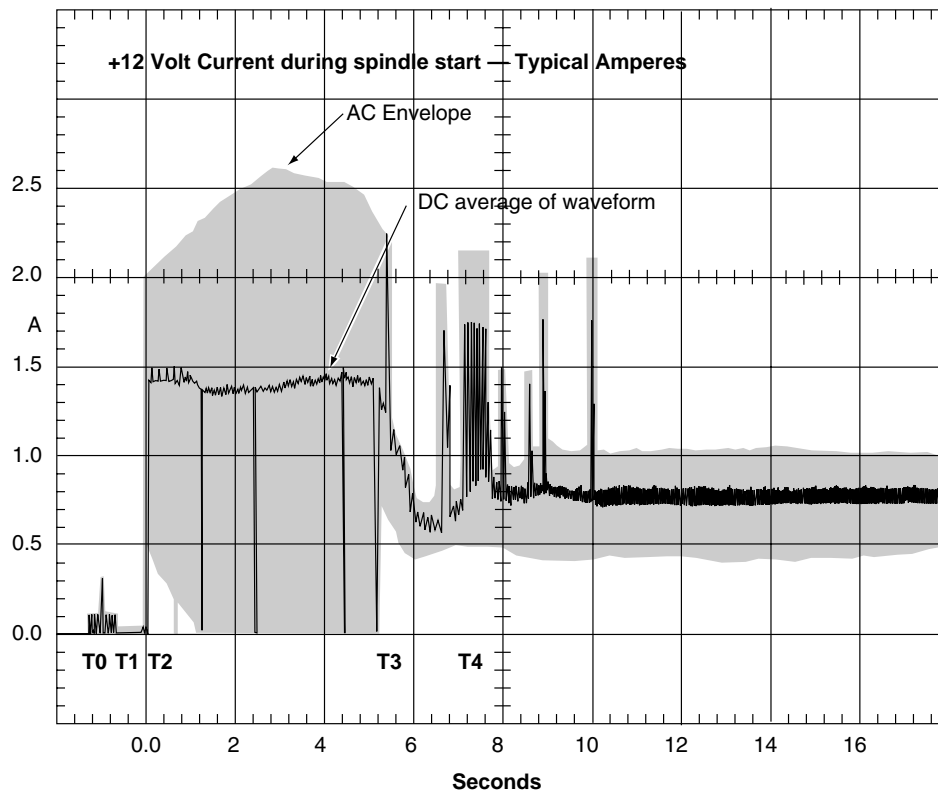

Figure 2. Typical ST336752 and ST336732 drive +12 V current profile

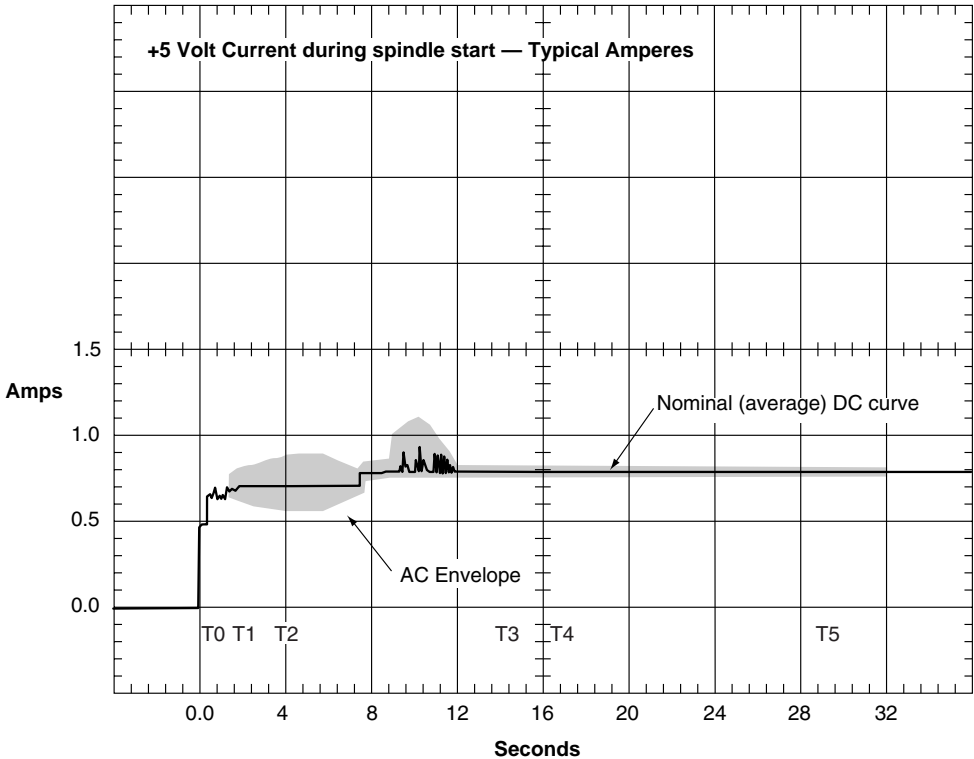

Figure 3. Typical ST336752 and ST336732 drive +5 V current profile

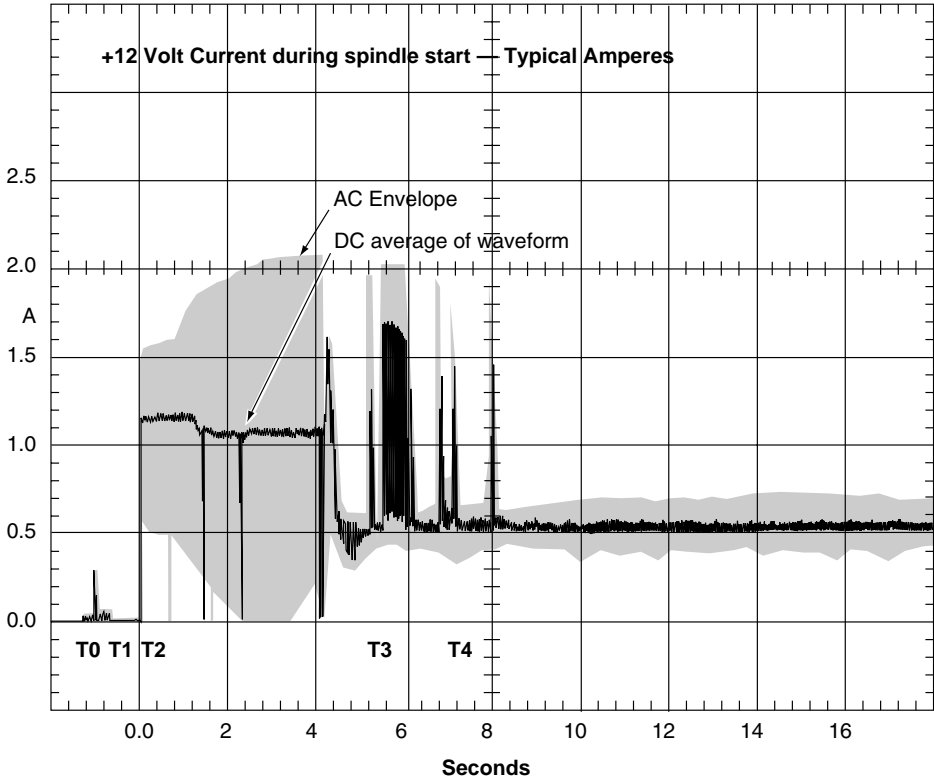

Figure 4. Typical ST318452 and ST318432 drive +12 V current profile

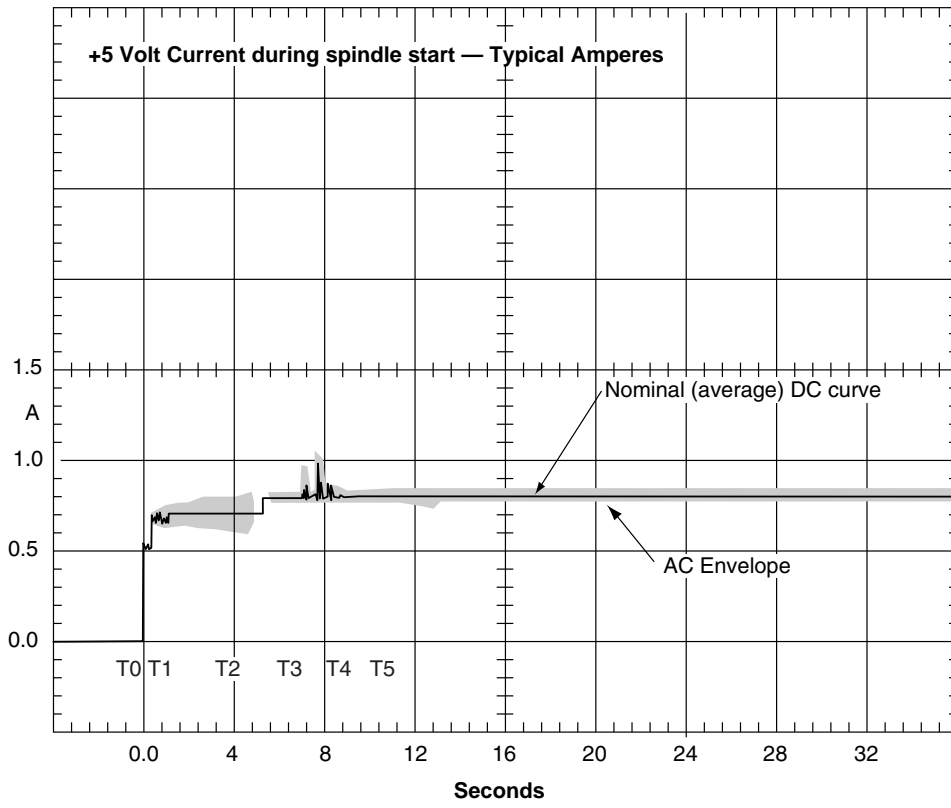

Figure 5. Typical ST318452 and ST318432 drive +5 V current profile

6.3 Power dissipation

ST336752 and ST336732

For drives using single-ended interface circuits, typical power dissipation under idle conditions is 12.1 watts (41.3 BTUs per hour).

For drives using low voltage differential interface circuits, typical power dissipation under idle conditions is 12.3 watts (42.0 BTUs per hour).

To obtain operating power for typical random read operations, refer to the following two I/O rate curves (see Figures 6 and 7). Locate the typical I/O rate for a drive in your system on the horizontal axis and read the corresponding +5 volt current, +12 volt current, and total watts on the vertical axis. To calculate BTUs per hour, multiply watts by 3.4123.

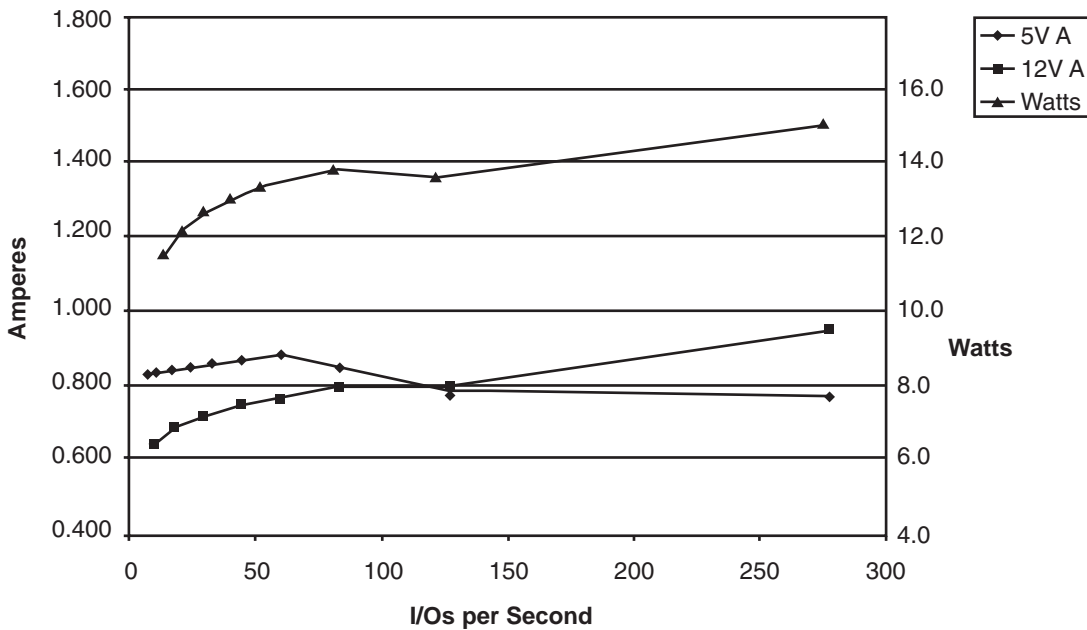

Figure 6. ST336752 and ST336732 DC current and power vs. IOPS (SE)

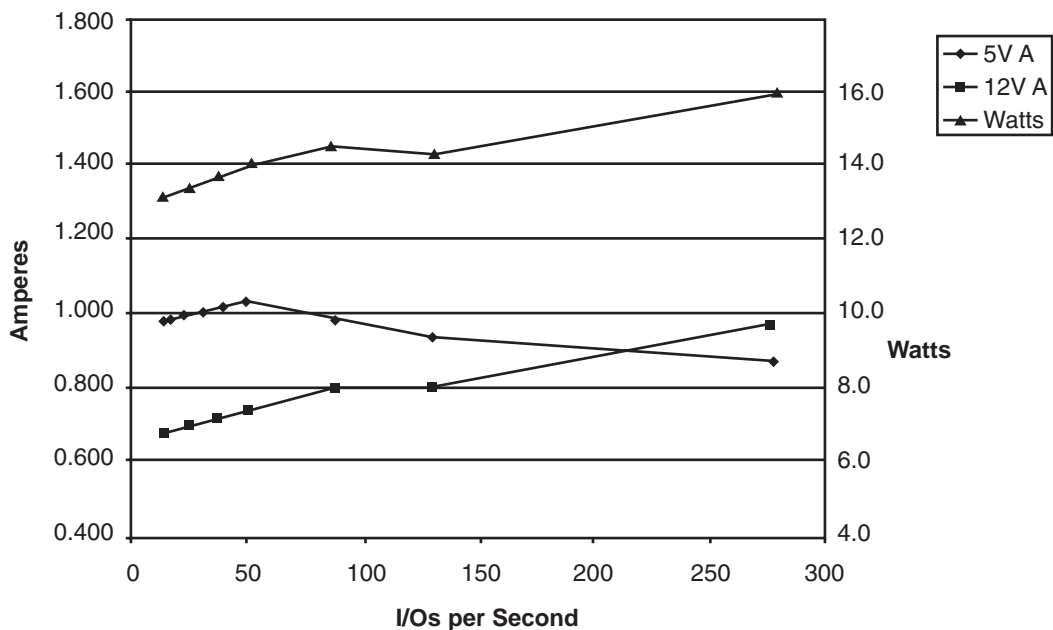

Figure 7. ST336752 and ST336732 DC current and power vs. IOPS (LVD)

ST318452 and ST318432

For drives using single-ended interface circuits, typical power dissipation under idle conditions is 10.0 watts (34.15 BTUs per hour).

For drives using low voltage differential interface circuits, typical power dissipation under idle conditions is 10.3 watts (35.18 BTUs per hour).

To obtain operating power for typical random read operations, refer to the following two I/O rate curves (see Figures 6 and 7). Locate the typical I/O rate for a drive in your system on the horizontal axis and read the corresponding +5 volt current, +12 volt current, and total watts on the vertical axis. To calculate BTUs per hour, multiply watts by 3.4123.

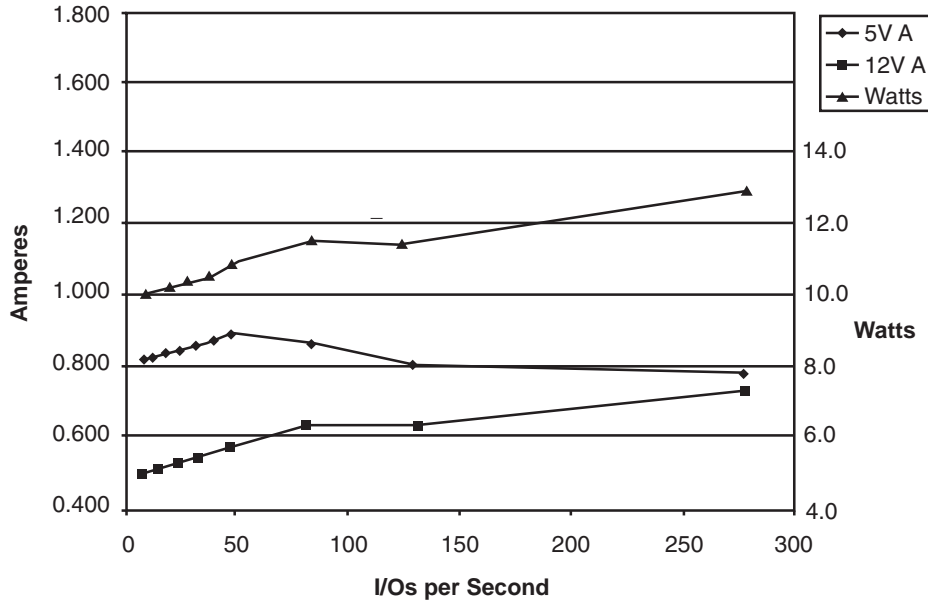

Figure 8. ST318452 and ST318432 DC current and power vs. IOPS (SE)

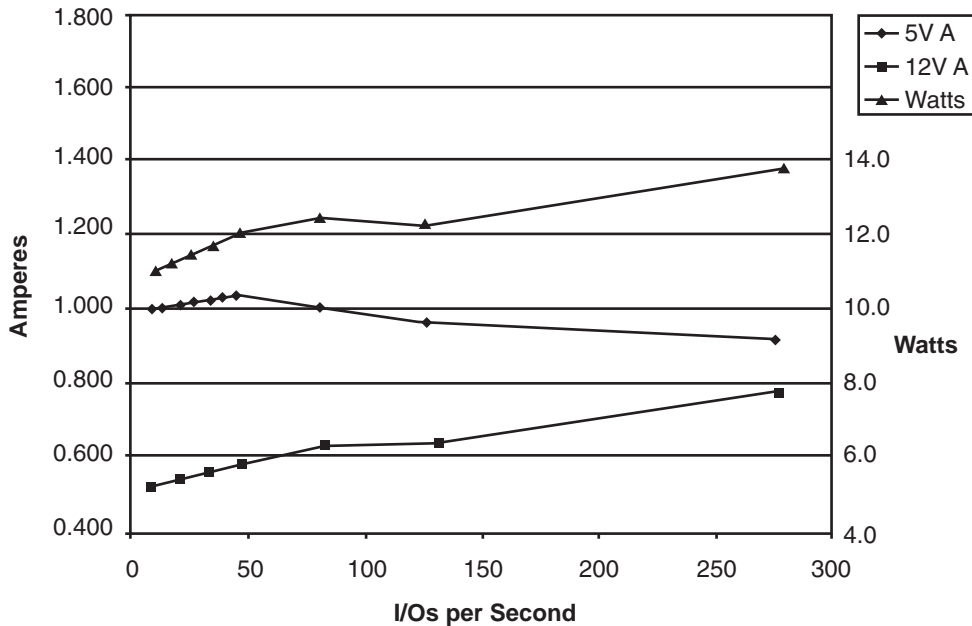

Figure 9. ST318452 and ST318432 DC current and power vs. IOPS (LVD)

6.4 Environmental limits

Temperature and humidity values experienced by the drive must be such that condensation does not occur on any drive part. Altitude and atmospheric pressure specifications are referenced to a standard day at 58.7°F (14.8°C). Maximum wet bulb temperature is 82°F (28°C).

6.4.1 Temperature

a. Operating

With cooling designed to maintain the case temperatures, the drive meets all specifications over a 41°F to 131°F (5°C to 55°C) drive ambient temperature range with a maximum temperature gradient of 36°F (20°C) per hour. The enclosure for the drive should be designed such that the temperatures are not exceeded. Air flow may be needed to achieve these temperature values (see Section 8.3). Operation at case temperatures above these values may adversely affect the drives ability to meet specifications.

The MTBF specification for the drive is based on operating in an environment that ensures that the case temperatures are not exceeded. Occasional excursions to drive ambient temperatures of 122°F (50°C) or 41°F (5°C) may occur without impact to specified MTBF. Air flow may be needed to achieve these temperatures. Continual or sustained operation at case temperatures above these values may degrade MTBF. The maximum allowable continuous or sustained HDA case temperature for the rated MTBF is 122°F (50°C)

To confirm that the required cooling for the electronics and HDA is provided, place the drive in its final mechanical configuration, perform random write/read operations. After the temperatures stabilize, measure the HDA case temperature of the drive.

The maximum allowable HDA case temperature is 60°C. Operation of the drive at the maximum case temperature is intended for short time periods only. Continuous operation at the elevated temperatures will reduce product reliability.

b. Non-operating

−40° to 158°F (−40° to 70°C) package ambient with a maximum gradient of 36°F (20°C) per hour. This specification assumes that the drive is packaged in the shipping container designed by Seagate for use with drive.

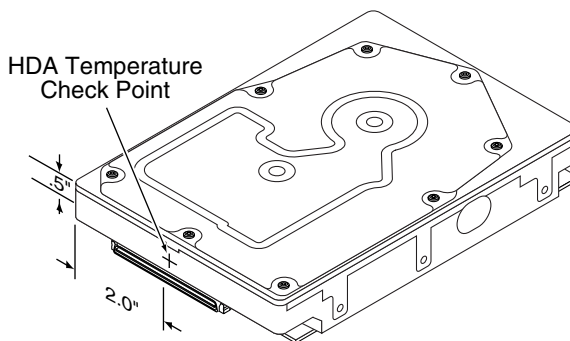

Figure 10. Locations of the HDA temperature check point

6.4.2 Relative humidity

The values below assume that no condensation on the drive occurs.

a. Operating

5% to 95% non-condensing relative humidity with a maximum gradient of 20% per hour.

b. Non-operating

5% to 95% non-condensing relative humidity.

6.4.3 Effective altitude (sea level)

a. Operating

−1,000 to +10,000 feet (−305 to +3,048 meters)

b. Non-operating

–1,000 to +40,000 feet (–305 to +12,210 meters)

6.4.4 Shock and vibration

Shock and vibration limits specified in this document are measured directly on the drive chassis. If the drive is installed in an enclosure to which the stated shock and/or vibration criteria is applied, resonances may occur internally to the enclosure resulting in drive movement in excess of the stated limits. If this situation is apparent, it may be necessary to modify the enclosure to minimize drive movement.

The limits of shock and vibration defined within this document are specified with the drive mounted by any of the four methods shown in Figure 11, and in accordance with the restrictions of Section 8.4. Orientation of the side nearest the LED may be up or down.

6.4.4.1 Shock

a. Operating—normal

The drive, as installed for normal operation, shall operate error free while subjected to intermittent shock not exceeding 15 Gs at a maximum duration of 11 msec (half sinewave). The drive, as installed for normal operation, shall operate error free while subjected to intermittent shock not exceeding 15 Gs at a maximum duration of 2 msec (half sinewave). Shock may be applied in the X, Y, or Z axis.

b. Operating—abnormal

Equipment, as installed for normal operation, does not incur physical damage while subjected to intermittent shock not exceeding 40 Gs at a maximum duration of 11 msec (half sinewave). Shock occurring at abnormal levels may promote degraded operational performance during the abnormal shock period. Specified operational performance will continue when normal operating shock levels resume. Shock may be applied in the X, Y, or Z axis. Shock is not to be repeated more than two times per second.

c. Non-operating

The limits of non-operating shock shall apply to all conditions of handling and transportation. This includes both isolated drives and integrated drives.

The drive subjected to nonrepetitive shock not exceeding 75 Gs at a maximum duration of 11 msec (half sinewave) shall not exhibit device damage or performance degradation. Shock may be applied in the X, Y, or Z axis.

The drive subjected to nonrepetitive shock not exceeding 250 Gs at a maximum duration of 2 msec (half sinewave) does not exhibit device damage or performance degradation. Shock may be applied in the X, Y, or Z axis.

The drive subjected to nonrepetitive shock not exceeding 100 Gs at a maximum duration of 0.5 msec (half sinewave) does not exhibit device damage or performance degradation. Shock may be applied in the X, Y, or Z axis.

d. Packaged

Disc drives shipped as loose load (not palletized) general freight will be packaged to withstand drops from heights as defined in the table below. For additional details refer to Seagate specifications 30190-001 (under 100 lbs/45 kg) or 30191-001 (over 100 lbs/45 Kg).

Package size	Packaged/product weight	Drop height
<600 cu in (<9,800 cu cm)	Any	60 in (1524 mm)
600-1800 cu in (9,800-19,700 cu cm)	0-20 lb (0 to 9.1 kg)	48 in (1219 mm)
>1800 cu in (>19,700 cu cm)	0-20 lb (0 to 9.1 kg)	42 in (1067 mm)
>600 cu in (>9,800 cu cm)	20-40 lb (9.1 to 18.1 kg)	36 in (914 mm)

Drives packaged in single or multipacks with a gross weight of 20 pounds (8.95 kg) or less by Seagate for general freight shipment shall withstand a drop test from 48 inches (1,070 mm) against a concrete floor or equivalent.

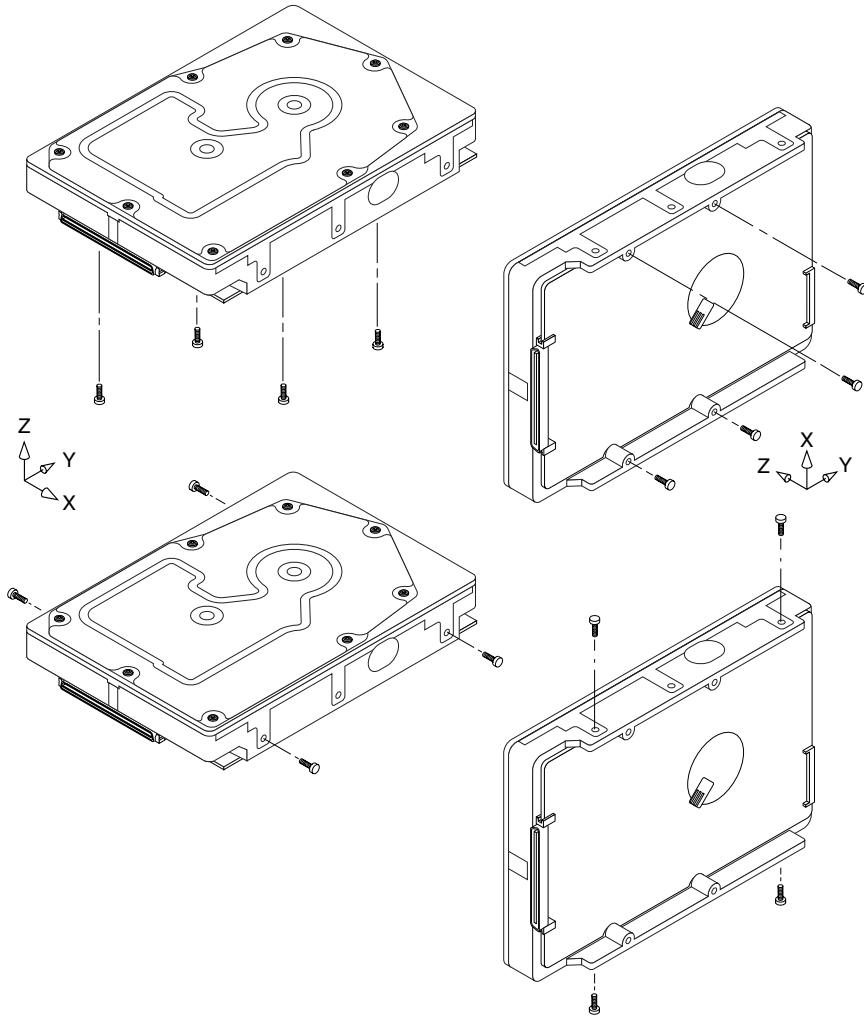

Figure 11. Recommended mounting

6.4.4.2 Vibration

a. Operating - normal

The drive as installed for normal operation, shall comply with the complete specified performance while subjected to continuous vibration not exceeding

5-500 Hz @ 0.5 G (zero to peak)

Vibration may be applied in the X, Y, or Z axis.

Operating normal translational random flat profile

10 - 400 Hz 0.4 GRMS

b. Operating - abnormal

Equipment as installed for normal operation shall not incur physical damage while subjected to periodic vibration not exceeding:

15 minutes of duration at major resonant frequency

5-500 Hz @ 0.75 G (X, Y, or Z axis, zero to peak)

Vibration occurring at these levels may degrade operational performance during the abnormal vibration period. Specified operational performance will continue when normal operating vibration levels are resumed. This assumes system recovery routines are available.

Operating abnormal translational random flat profile

10 - 400 Hz 1.2 GRMS

c. Non-operating

The limits of non-operating vibration shall apply to all conditions of handling and transportation. This includes both isolated drives and integrated drives.

The drive shall not incur physical damage or degraded performance as a result of continuous vibration not exceeding

5-22 Hz @ 0.040 inches (1.02 mm) displacement (zero to peak)

22-500 Hz @ 2.00 G (zero to peak)

Vibration may be applied in the X, Y, or Z axis.

Non-operating translational random flat profile

10 - 400 Hz 1.2 GRMS

6.4.5 Air cleanliness

The drive is designed to operate in a typical office environment with minimal environmental control.

6.4.6 Acoustics

Sound power during idle mode shall be 3.7 bels typical when measured to ISO 7779 specification.

There will not be any discrete tones more than 10 dB above the masking noise on typical drives when measured according to Seagate specification 30553-001. There will not be any tones more than 24 dB above the masking noise on any drive.

6.4.7 Electromagnetic susceptibility

See Section 2.1.2.

6.5 Mechanical specifications

The following nominal dimensions are exclusive of the decorative front panel accessory. However, dimensions of the front panel are shown in figure below. Refer to Figures 12 and 13 for detailed mounting configuration dimensions. See Section 8.4, "Drive mounting."

Height:	1.000 in	25.4 mm
Width:	4.000 in	101.6 mm
Depth:	5.75 in	146.05 mm
Weight:	1.8 pounds	0.816 kilograms

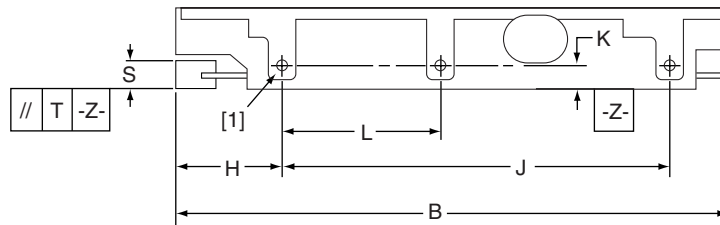

Notes:

[1] Mounting holes are 6-32 UNC 2B, three on each side and four on the bottom. Max screw penetration into side of drive is 0.15 in. (3.81 mm). Max screw tightening torque is 8.0 in-lb (4.43 nm) with minimum full thread engagement of 0.12 in. (3.05 mm).

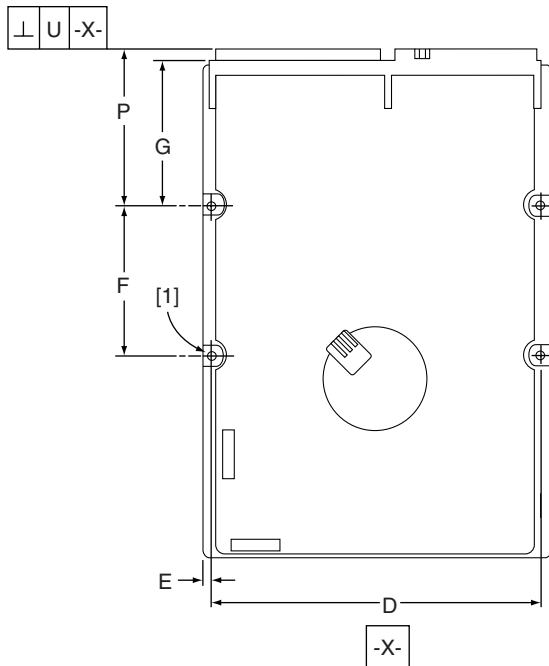
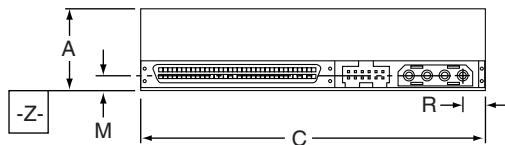

Dimension Table

	Inches	Millimeters
A	1.028 max	26.10 max
B	5.787 max	147.00 max
C	4.000 - .010	101.60 - .25
D	3.750 - .010	92.25 - .25
E	.125 - .010	3.18 - .25
F	1.750 - .010	44.45 - .25
G	1.625 - .020	41.28 - .50
H	1.122 - .020	28.50 - .50
J	4.000 - .010	101.60 - .25
K	.250 - .010	6.35 - .25
L	1.638 - .010	41.60 - .25
M	.181 - .020	4.60 - .50
P	1.625 - .020	41.28 - .50
R	.265 - .010	6.73 - .25
S	.315 - .040	7.00 - 1.02
T	.015 max	0.38 max
U	.015 max	0.38 max

Figure 12. LW mounting configuration dimensions

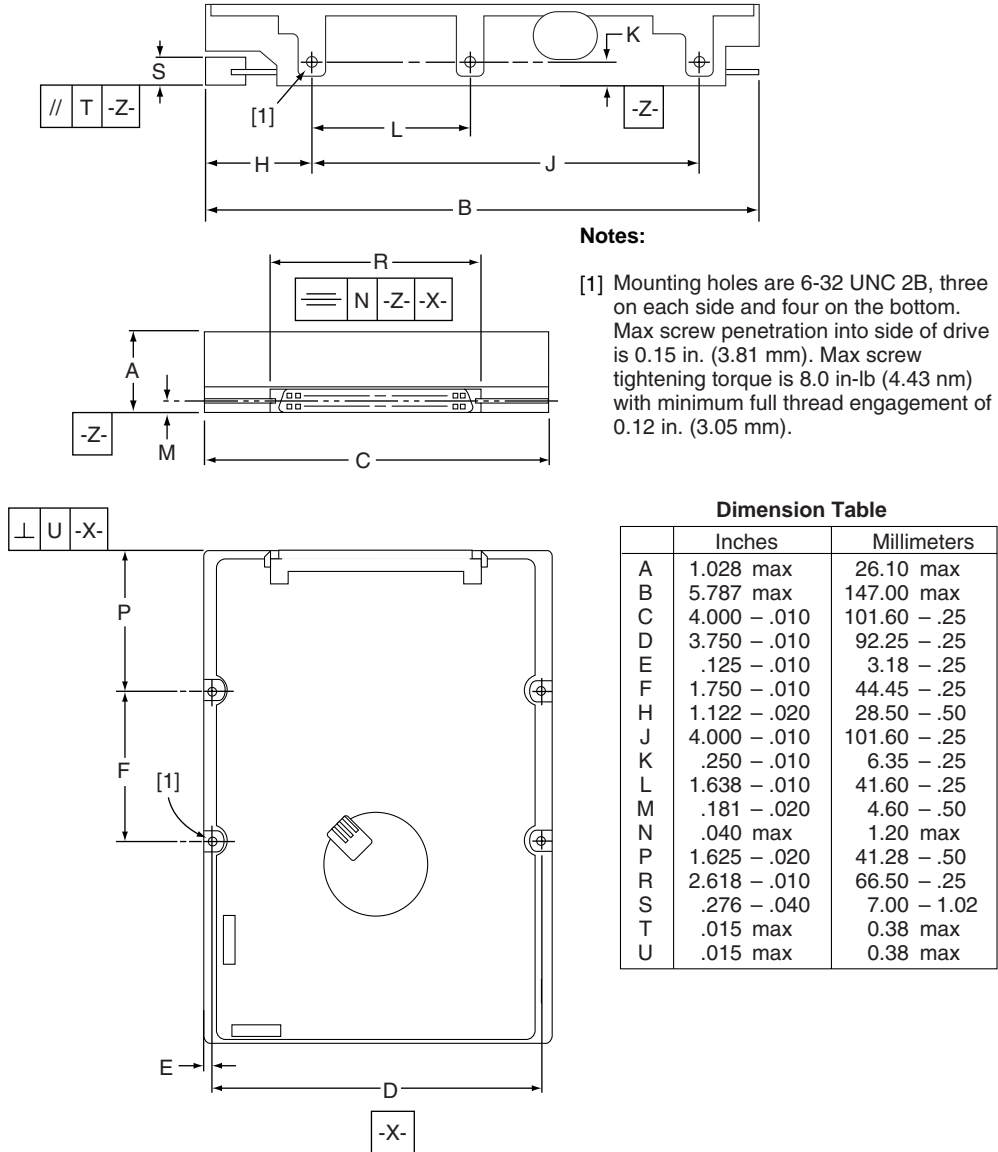

Figure 13. LC mounting configuration dimensions

7.0 Defect and error management

The drive, as delivered, complies with this specification. The read error rate and specified storage capacity are not dependent upon use of defect management routines by the host (initiator).

Defect and error management in the SCSI system involves the drive internal defect/error management and SCSI systems error considerations (errors in communications between Initiator and the drive). Tools for use in designing a defect/error management plan are briefly outlined in this section, with references to other sections where further details are given.

7.1 Drive internal defects

During the initial drive format operation at the factory, media defects are identified, tagged as being unusable, and their locations recorded on the drive primary defects list (referred to as the “P” list and also as the ETF defect list). At factory format time, these known defects are also reallocated, that is, reassigned to a new place on the medium and the location listed in the defects reallocation table. The “P” list is not altered after factory formatting. Locations of defects found and reallocated during error recovery procedures after drive shipment are listed in the “G” list (defects growth list). The “P” and “G” lists may be referenced by the initiator using the Read Defect Data command (see the *SCSI Interface Product Manual*).

7.2 Drive error recovery procedures

Whenever an error occurs during drive operation, the drive, if programmed to do so, performs error recovery procedures to attempt to recover the data. The error recovery procedures used depend on the options previously set up in the error recovery parameters mode page. Error recovery and defect management may involve the use of several SCSI commands, the details of which are described in the *SCSI Interface Product Manual*. The drive implements selectable error recovery time limits such as are required in video applications. For additional information on this, refer to the Error Recovery Page table in the *SCSI Interface Product Manual*, which describes the Mode Select/Mode Sense Error Recovery parameters.

The error recovery scheme supported by the drive provides a means to control the total error recovery time for the entire command in addition to controlling the recovery level for a single LBA. The total amount of time spent in error recovery for a command can be limited via the Recovery Time Limit bytes in the Error Recovery Mode Page. The total amount of time spent in error recovery for a single LBA can be limited via the Read Retry Count or Write Retry Count bytes in the Error Recovery Mode Page.

The drive firmware error recovery algorithms consist of 11 levels for read recoveries and 5 levels for writes.

Table 4 equates the Read and Write Retry Count with the maximum possible recovery time for read and write recovery of individual LBAs. The times given do not include time taken to perform reallocations, if reallocations are performed. Reallocations are performed when the ARRE bit (for reads) or AWRE bit (for writes) is one, the RC bit is zero, and the Recovery Time Limit for the command has not yet been met. Time needed to perform reallocation is not counted against the Recovery Time Limit.

The Read Continuous (RC) bit, when set to one, requests the disc drive to transfer the requested data length without adding delays (for retries or ECC correction) that may be required to insure data integrity. The disc drive may send erroneous data in order to maintain the continuous flow of data. The RC bit should only be used when data integrity is not a concern and speed is of utmost importance. If the Recovery Time Limit or retry count is reached during error recovery, the state of the RC bit is examined. If the RC bit is set, the drive will transfer the unrecovered data with no error indication and continue to execute the remaining command. If the RC bit is not set, the drive will stop data transfer with the last good LBA, and report a “Check Condition, Unrecovered Read Error.”

Table 4: Read and write retry count maximum recovery times [1]

Read retry count [1]	Maximum recovery time per LBA (cumulative, msec)	Write retry count	Maximum recovery time per LBA (cumulative, msec)
0	52.0	0	35.8
1	60.0	1	53.7
2	203.9	2	59.7
3	220.0	3	113.6
4	243.9	4	227.1
5	275.9	5 (default)	268.9
6	347.8		
7	355.8		
8	371.8		
9	407.8		
10	433.5		
11 (default)	1,033.1		

[1] These values are subject to change.

Setting these retry counts to a value below the default setting could result in an increased unrecovered error rate which may exceed the value given in this product manual. A setting of zero (0) will result in the drive not performing error recovery.

For example, suppose the Read/Write Recovery page has the RC bit set to 0, read retry count set to 4, and the recovery time limit field (Mode Sense page 01, bytes 10 and 11) set to FF FF hex (maximum). A four LBA Read command is allowed to take up to 244 msec recovery time for each of the four LBAs in the command. If the recovery time limit is set to 00 C8 hex (200 msec decimal) a four LBA read command is allowed to take up to 200 msec for all error recovery within that command. The use of the Recovery Time Limit field allows finer granularity on control of the time spent in error recovery. The recovery time limit only starts counting when the drive is executing error recovery and it restarts on each command. Therefore, each command's total recovery time is subject to the recovery time limit. Note: A recovery time limit of 0 will use the drive's default value of FF FF. Minimum recovery time limit is achieved by setting the Recovery Time Limit field to 00 01.

7.3 SCSI systems errors

Information on the reporting of operational errors or faults across the interface is given in the *SCSI Interface Product Manual*. Message Protocol System is described in the *SCSI Interface Product Manual*. Several of the messages are used in the SCSI systems error management system. The Request Sense command returns information to the host about numerous kinds of errors or faults. The Receive Diagnostic Results reports the results of diagnostic operations performed by the drive.

Status returned by the drive to the Initiator is described in the *SCSI Interface Product Manual*. Status reporting plays a role in the SCSI systems error management and its use in that respect is described in sections where the various commands are discussed.

8.0 Installation

Note. These drives are designed to be used only on single-ended (SE) or low voltage differential (LVD) buses. Do not install these drives on a high voltage differential (HVD) bus.

The first thing to do when installing a drive is to set the drive SCSI ID and set up certain operating options. This is usually done by installing small shorting jumpers on the pins of connectors J2 and J6 on the PCBA (or J1-Auxiliary on the LW model), or via the drive to host I/O signals on the LC model. Some users connect cables to J6 or J5-Auxiliary and perform the set-up using remote switches.

Configure drive options

For option jumper locations and definitions refer to Figures 14, 15, and 16. Drive default mode parameters are not normally needed for installation. Refer to Section 9.3.2 for default mode parameters if they are needed.

- Ensure that the SCSI ID of the drive is not the same as the host adapter. Most host adapters use SCSI ID 7 because ID 7 is the highest priority on both 8 and 16 bit data buses.
- If multiple devices are on the bus set the drive SCSI ID to one that is not presently used by other devices on the bus.
- If the drive is the only device on the bus, attach it to the end of the SCSI bus cable. The user, system integrator, or host equipment manufacturer must provide external terminators.

Note. For additional information about terminator requirements, refer to Sections 9.8 and 9.9.

- Set all appropriate option jumpers for desired operation prior to power on. If jumpers are changed after power has been applied, recycle the drive power to make the new settings effective.
- Installation instructions are provided by host system documentation or with any additionally purchased drive installation software. If necessary see Section 10 for Seagate support services telephone numbers.
- Do not remove the manufacturer's installed labels from the drive and do not cover with additional labels, as the manufacturer labels contain information required when servicing the product.

Formatting

- It is not necessary to low level format this drive. The drive is shipped from the factory low level formatted in 512 byte sectors.
- Reformat the drive if a different spare sector allocation scheme is selected.
- High level formatting the drive involves assigning one or more partitions or logical drives to the drive volume. Follow the instructions in the system manuals for the system into which the drive is to be installed.

8.1 Drive ID/option select header

Figures 14 and 15 show views of the drive ID select jumper connectors. Figure 16 shows the option select jumper connector for all models. Figure 14 shows the drive's J5-auxiliary jumper connector. Both J5-auxiliary and J6 have pins for selecting drive ID and for connecting the remote LED cable. Only one or the other should be used, although using both at the same time would not damage the drive. The notes following the figures describe the functions of the various jumper positions on the connectors J2, J5-Auxiliary and J6. Suggested part number for the jumpers used on J2 is Molex 52747-0211 (Seagate part number 77679052). A bag with the two jumper plug types is shipped with the standard OEM drives.

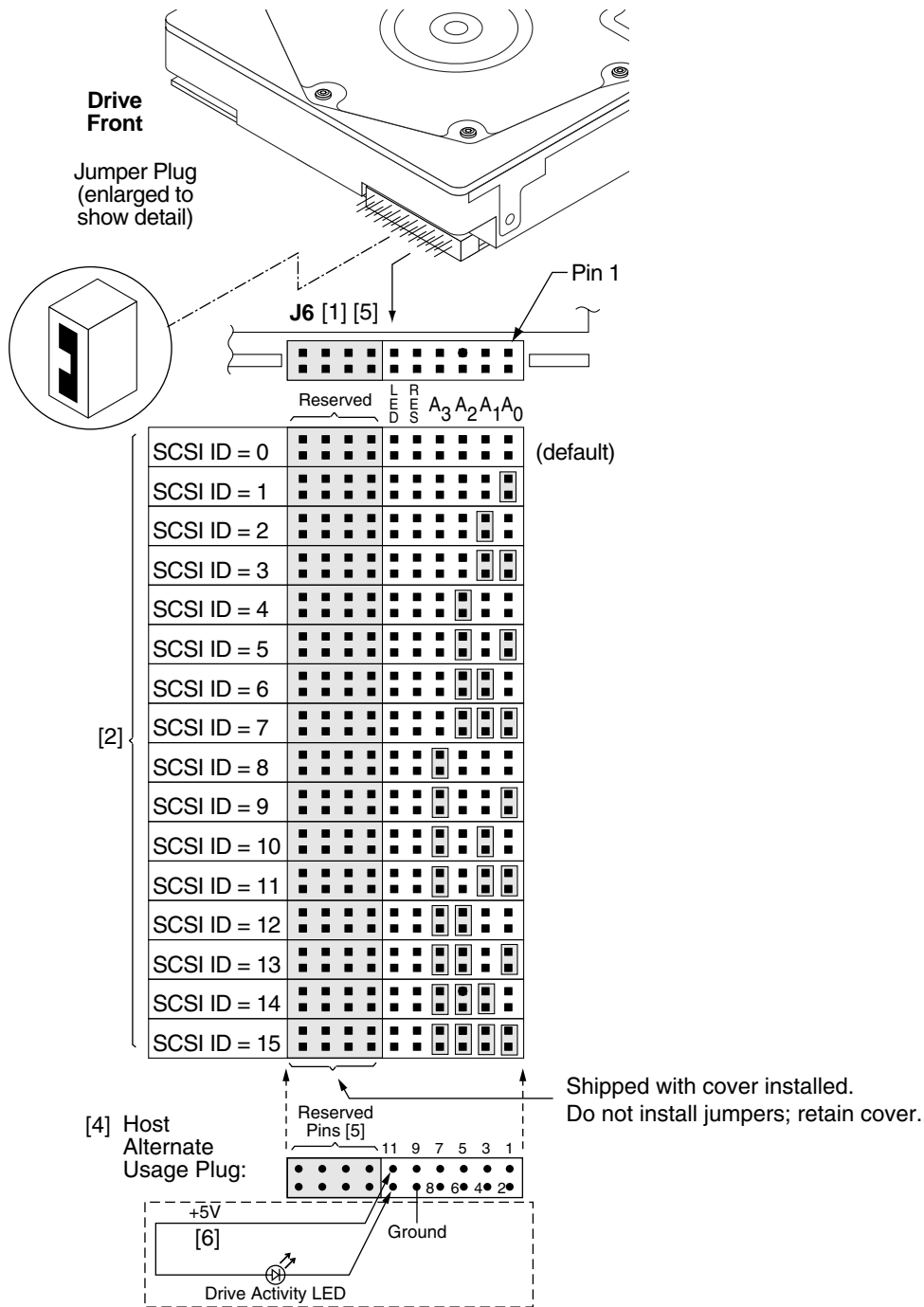

[4] Dashed area is optional host circuitry (external to the drive) connected to host supplied optional usage plug.

[5] Do not connect anything to pins 13-20.

Figure 14. J6 jumper header

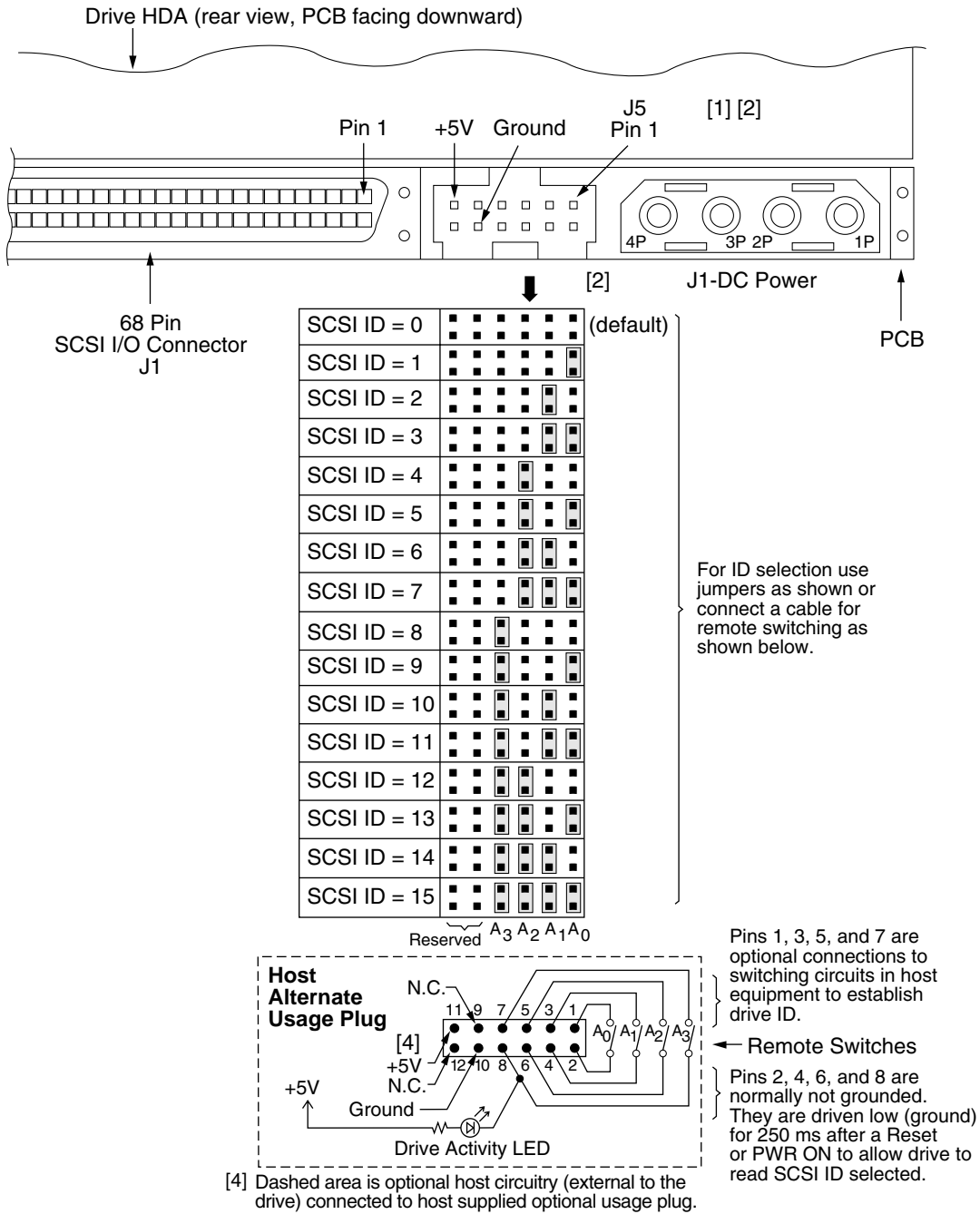

Figure 15. J5 jumper header (on LW models only)

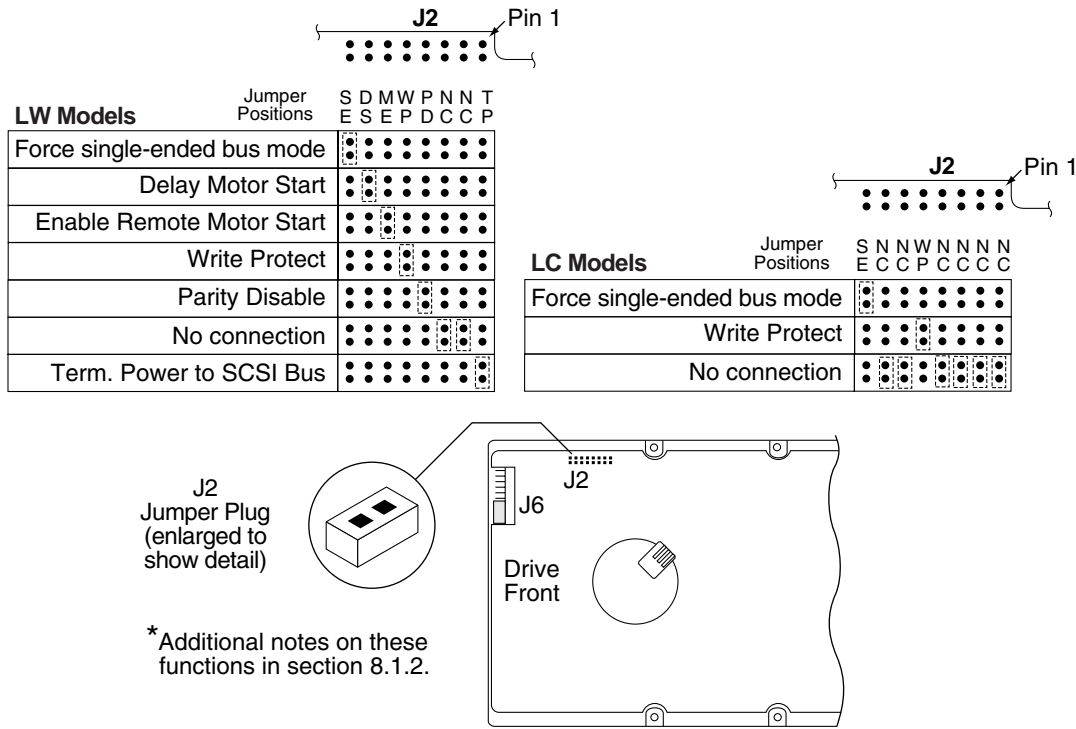

Figure 16. J2 option select header (on LW models only)

8.1.1 Notes for Figures 14, 15, and 16.

[1] Notes explaining the functions of the various jumpers on jumper header connectors J2, J5, and J6 are provided in Section 8.1.2. The term “**default**” indicates how standard OEM units are configured when shipped from factory. “Off” means the jumper is not installed; “On” means a jumper is installed. OFF or ON underlined indicates the factory **default** condition.

The PCBA on LC models does not have connector J5. The J5 connector signals conform to SFF-8009 Revision 2.0, Unitized Connector for Cabled Drives, signal assignments for auxiliary connectors.

- [2] These signals are also on the 80-pin J1 I/O connector. See Tables 18 and 19.
- [3] Voltage supplied by the drive.
- [4] Dashed area is optional host circuitry (external to the drive) connected to host-supplied optional usage plug.
- [5] Do not connect anything to J5 pins 9, 11-12, or J6 pins 13-20.
- [6] Connect an external Drive Activity LED to J6 pins 11 and 12, or to J5 pin 8 and the drive’s +5V power source, through an appropriately-sized current-limiting resistor. The drive provides an internal 150 ohm current-limiting resistor for the J6 connection.

8.1.2 Function description

J2**jumper****installation****Jumper function description****SE**

On

Forces drive to use single-ended I/O drivers/receivers only.

OffDrive can operate on the interface in low voltage differential mode or single-ended, depending on the voltage state of the I/O "DIFFSENS" line. **Default.****DS ME****(Does not apply to LC models)**OffOffSpindle starts immediately after power up. **Default.**

Off

On

Drive spindle does not start until the Start Unit command received from the host.

On

Off

Spindle startup is delayed by the SCSI ID times 12 seconds after power is applied, i.e., the drive assigned SCSI ID 0 spindle starts immediately when DC power is connected, a drive assigned SCSI ID 1 starts after 12-second delay, and a drive assigned SCSI ID 2 starts after 24-second delay, etc.

On

On

Drive spindle starts when the Start Unit command is received from the host. The Delayed Start feature is overridden and does not apply when the **ME** jumper is installed.**WP**

On

Entire drive is write protected.

OffDrive is not write protected. **Default.****PD****(Does not apply to LC models)**

On

Parity checking and parity error reporting by the drive is disabled.

OffDrive checks for parity and reports result of parity checking to host. **Default.****NC**OffNo connection. **Default.****TP****(Does not apply to LC models)**

Off

The drive does not supply terminator power to external terminators or to the SCSI bus I/O cable.

On

Drive supplies power to SCSI bus I/O cable. When drives have differential I/O circuits, a jumper on the **TP1** position may be needed to power external terminators (see system documentation). These drives do not have terminator circuits on the drive.

8.2 Drive orientation

The balanced rotary arm actuator design of the drive allows it to be mounted in any orientation. All drive performance characterization, however, has been done with the drive in horizontal (discs level) and vertical (drive on its side) orientations, and these are the two preferred mounting orientations.

8.3 Cooling

Cabinet cooling must be designed by the customer so that the ambient temperature immediately surrounding the drive will not exceed temperature conditions specified in Section 6.4.1, “Temperature.”

The rack, cabinet, or drawer environment for the drive must provide heat removal from the electronics and head and disc assembly (HDA). You should confirm that adequate heat removal is provided using the temperature measurement guidelines described in Section 6.4.1.

Forced air flow may be required to keep temperatures at or below the temperatures specified in Section 6.4.1 in which case the drive should be oriented, or air flow directed, so that the least amount of air flow resistance is created while providing air flow to the electronics and HDA. Also, the shortest possible path between the air inlet and exit should be chosen to minimize the travel length of air heated by the drive and other heat sources within the rack, cabinet, or drawer environment.

If forced air is determined to be necessary, possible air-flow patterns are shown in Figure 17. The air-flow patterns are created by one or more fans, either forcing or drawing air as shown in the illustrations. Conduction, convection, or other forced air-flow patterns are acceptable as long as the temperature measurement guidelines of Section 6.4.1 are met.

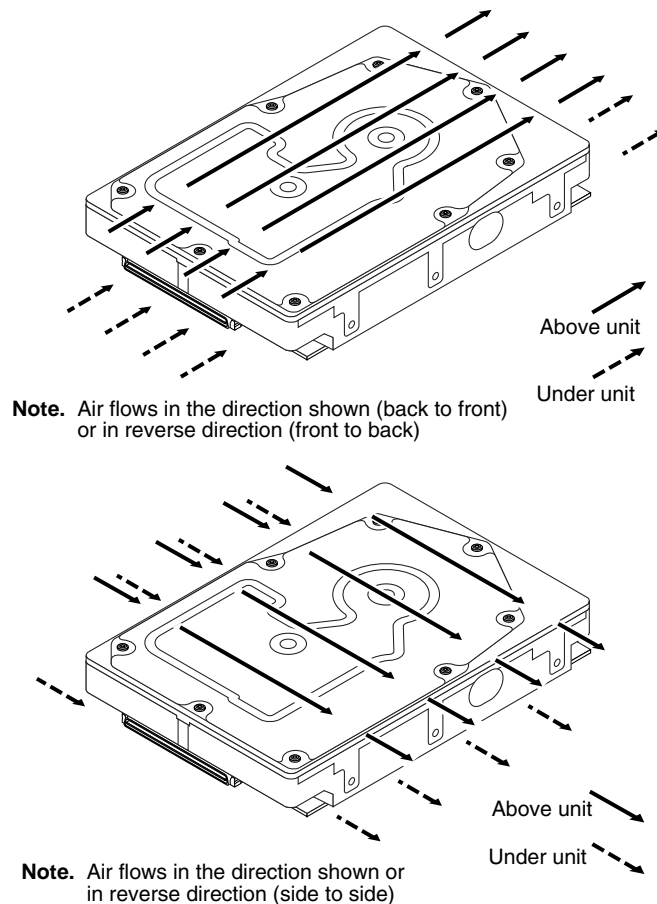

Figure 17. Air flow (suggested)

8.4 Drive mounting

When mounting the drive using the bottom holes (x-y plane in Figure 11) care must be taken to ensure that the drive is not physically distorted due to a stiff non-flat mounting surface. The allowable mounting surface stiffness is 80 lb/in (14.0 N/mm). The following equation and paragraph define the allowable mounting surface stiffness:

$$k * x = F \leq 15\text{lb} = 67\text{N}$$

where 'k' represents the mounting surface stiffness (units of lb/in or N/mm), and 'x' represents the out-of-plane mounting surface distortion (units of inches or millimeters). The out-of-plane distortion ('x') is determined by defining a plane with three of the four mounting points fixed and evaluating the out-of-plane deflection of the fourth mounting point when a known force (F) is applied to the fourth point.

Note. Before mounting the drive in any kind of 3.5-inch to 5.25-inch adapter frame, verify with Seagate Technology that the drive can meet the shock and vibration specifications given herein while mounted in such an adapter frame. Adapter frames that are available may not have a mechanical structure capable of mounting the drive so that it can meet the shock and vibration specifications listed in this manual.

8.5 Grounding

Signal ground (PCBA) and HDA ground are connected together in the drive and cannot be separated by the user. The equipment in which the drive is mounted is connected directly to the HDA and PCBA with no electrically isolating shock mounts. If it is desired for the system chassis to not be connected to the HDA/PCBA ground, the systems integrator or user must provide a nonconductive (electrically isolating) method of mounting the drive in the host equipment.

Increased radiated emissions may result if you do not provide the maximum surface area ground connection between system ground and drive ground. This is the system designer's and integrator's responsibility.

9.0 Interface requirements

This section partially describes the interface requirements as implemented on the drives.

9.1 General description

This section describes in essentially general terms the interface requirements supported by the Cheetah X15 36LP. No attempt is made to describe all of the minute details of conditions and constraints that must be considered by designers when designing a system in which this family of drives can properly operate. Seagate declares that the drives operate in accordance with the appropriate ANSI Standards referenced in various places herein, with exceptions as noted herein or in the *Seagate SCSI Interface Product Manual*.

9.2 SCSI interface messages supported

Table 5 lists the messages supported by Cheetah X15 36LP family drives.

Table 5: SCSI messages supported by Cheetah X15 36LP family drives

Message name	Message code	Supported by ST336752 and ST318452 models	Supported by ST336732 and ST318432 models
Abort	06h	Y	Y
Abort-tag	0Dh	Y	Y
Bus device reset	0Ch	Y	Y
Clear ACA	16h	N	N
Clear queue	0Eh	Y	Y
Command complete	00h	Y	Y
Continue I/O process	12h	N	N
Disconnect	04h	Y	Y
Extended messages	01h[1]	Y	Y
Identify	80h-FFh	Y	Y
Ignore wide residue (two bytes)	23h	Y	Y
Initiate recovery	0Fh	N	N
Initiator detected error	05h	Y	Y
Linked command complete	0Ah	Y	Y
Linked command complete with flag	0Bh	Y	Y
Message parity error	09h	Y	Y
Message reject	07h	Y	Y
Modify data pointer	[1]	N	N
No operation	08h	Y	Y
Parallel Protocol Request		Y [1] [2]	Y
Queue tag messages (two bytes)			
ACA	24h	N	N
Head of queue tag	21h	Y	Y
Ordered queue tag	22h	Y	Y
Simple queue tag	20h	Y	Y
Quick Arbitration and Selection (QAS)	55h	N	Y
Release recovery	10h	N	N
Restore pointers	03h	Y	Y
Save data pointer	02h	Y	Y
Synchronous data transfer req.	[1]	Y	Y
Target transfer disable	13h	N	N
Terminate I/O process	11h	N	N
Wide data transfer request	[1]	Y	Y

Notes.

- [1] Extended messages (see the *SCSI Interface Product Manual*).
 [2] Supports all options except `qas_req` and `iu_req`.

9.3 SCSI interface commands supported

Table 6 following lists the SCSI interface commands that are supported by the drive.
 ST336752 and ST318452 OEM standard drives are shipped set to operate in Ultra160 mode.
 ST336732 and ST318432 OEM standard drives are shipped set to operate in Ultra320 mode.

Table 6: Commands supported by Cheetah X15 36LP family drive

Command name	Command code	Supported by ST336752 and ST318452 models	Supported by ST336732 and ST318432 models
Change Definition	40h	N	N
Compare	39h	N	N
Copy	18h	N	N
Copy and Verify	3Ah	N	N
Format Unit [1]	04h	Y	Y
DPRY bit supported		N	N
DCRT bit supported		Y	Y
STPF bit supported		Y	Y
IP bit supported		Y	Y
DSP bit supported		Y	Y
IMMED bit supported		Y	Y
VS (vendor specific)		N	N
Inquiry	12h	Y	Y
Date Code page (C1h)		Y	Y
Device Behavior page (C3h)		Y	Y
Firmware Numbers page (C0h)		Y	Y
Implemented Operating Def page (81h)		Y	Y
Jumper Settings page (C2h)		Y	Y
Supported Vital Product Data page (00h)		Y	Y
Unit Serial Number page (80h)		Y	Y
Lock-unlock cache	36h	N	N
Log Select	4Ch	Y	Y
PCR bit		Y	Y
DU bit		N	N
DS bit		Y	Y
TSD bit		Y	Y
ETC bit		N	N
TMC bit		N	N
LP bit		N	N
Log Sense	4Dh	Y	Y
Application Client Log page (0Fh)		Y	Y
Buffer Over-run/Under-run page (01h)		N	N
Cache Statistics page (37h)		Y	Y
Factory Log page (3Eh)		Y	Y
Last n Deferred Errors or Asynchronous Events page (0Bh)		N	N
Last n Error Events page (07h)		N	N
Non-medium Error page (06h)		Y	Y
Pages Supported list (00h)		Y	Y

Table 6: Commands supported by Cheetah X15 36LP family drive (Continued)

Command name	Command code	Supported by ST336752 and ST318452 models	Supported by ST336732 and ST318432 models
Read Error Counter page (03h)		Y	Y
Read Reverse Error Counter page (04h)		N	N
Self-test Results page (10h)		Y	Y
Start-stop Cycle Counter page (0Eh)		Y	Y
Temperature page (0Dh)		Y	Y
Verify Error Counter page (05h)		Y	Y
Write error counter page (02h)		Y	Y
Mode Select (same pages as Mode Sense 1Ah)	15h	Y [2]	Y [2]
Mode Select (10) (same pages as Mode Sense 1Ah)	55h	Y	Y
Mode Sense	1Ah	Y [2]	Y [2]
Caching Parameters page (08h)		Y	Y
Control Mode page (0Ah)		Y	Y
Disconnect/Reconnect (02h)		Y	Y
Error Recovery page (01h)		Y	Y
Format page (03h)		Y	Y
Information Exceptions Control page (1Ch)		Y	Y
Notch and Partition Page (0Ch)		N	N
Port Control Page (19h)		N	Y
Power Condition page (1Ah)		Y	Y
Rigid Disc Drive Geometry page (04h)		Y	Y
Unit Attention page (00h)		Y	Y
Verify Error Recovery page (07h)		Y	Y
Xor Control page (10h)		N	N
Mode Sense (10) (same pages as Mode Sense 1Ah)	5Ah	Y	Y
Prefetch	34h	N	N
Read	08h	Y	Y
Read Buffer (modes 0, 2, 3, Ah and Bh supported)	3Ch	Y	Y
Read Capacity	25h	Y	Y
Read Defect Data (10)	37h	Y	Y
Read Defect Data (12)	B7h	Y	Y
Read Extended	28h	Y	Y
DPO bit supported		Y	Y
FUA bit supported		Y	Y
Read Long	3Eh	Y	Y
Reassign Blocks	07h	Y	Y
Receive Diagnostic Results	1Ch	Y	Y
Supported Diagnostics pages (00h)		Y	Y
Translate page (40h)		Y	Y
Release	17h	Y	Y
Release (10)	57h	Y	Y
Request Sense	03h	Y	Y
Actual Retry Count bytes		Y	Y
Extended Sense		Y	Y
Field Pointer bytes		Y	Y
Reserve	16h	Y	Y

Table 6: Commands supported by Cheetah X15 36LP family drive (Continued)

Command name	Command code	Supported by ST336752 and ST318452 models	Supported by ST336732 and ST318432 models
3rd Party Reserve		Y	Y
Extent Reservation		N	N
Reserve (10)	56h	Y	Y
3rd Party Reserve		Y	Y
Extent Reservation		N	N
Rezero Unit	01h	Y	Y
Search Data Equal	31h	N	N
Search Data High	30h	N	N
Search Data Low	32h	N	N
Seek	0Bh	Y	Y
Seek Extended	2Bh	Y	Y
Send Diagnostics	1Dh	Y	Y
Supported Diagnostics pages (00h)		Y	Y
Translate page (40h)		Y	Y
Set Limits	33h	N	N
Start Unit/Stop Unit (spindle ceases rotating)	1Bh	Y	Y
Synchronize Cache	35h	Y	Y
Test Unit Ready	00h	Y	Y
Verify	2Fh	Y	Y
BYTCHK bit		Y	Y
Write	0Ah	Y	Y
Write and Verify	2Eh	Y	Y
DPO bit		Y	Y
Write Buffer (modes 0, 2, supported)	3Bh	Y	Y
Firmware Download option (modes 5, 7, Ah and Bh supported) [3]		Y	Y
Write Extended	2Ah	Y	Y
DPO bit		Y	Y
FUA bit		Y	Y
Write Long	3Fh	Y	Y
Write Same	41h	Y	Y
PBdata		N	N
LBdata		N	N
XDRead	52h	N	N
XDWrite	50h	N	N
XPWrite	51h	N	N

[1] The drive can format to any even number of bytes per sector from 512 to 704.

[2] Tables 8 show how individual bits are set and which are changeable by the host.

[3] **WARNING:** A power loss during flash programming can result in firmware corruption. This usually makes the drive inoperable.

Table 7 lists the Standard Inquiry command data that the drive should return to the initiator per the format given in the *SCSI Interface Product Manual*, part number 75789509, Inquiry command section.

Table 7: Cheetah X15 36LP family drive Standard Inquiry data

Bytes	Data (HEX)																
0-15	00	00	[03] ¹	[12] ²	8B	00	01	3E	53	45	41	47	41	54	45	20	VENDOR ID
16-31	53	54	[33]	[33]	[36]	[37]	[35]	[32]	[4C]	[57]	[20] ³	20	20	20	20	20	PRODUCT ID
32-47	R#	R#	R#	R#	S#	S#	S#	S#	S#	S#	S#	S#	00	00	00	00	
48-63	00	00	00	00	00	00	00	00	00	00	00	00	00	00	00	00	
64-79	00	00	00	00	00	00	00	00	00	00	00	00	00	00	00	00	
80-95	00	00	00	00	00	00	00	00	00	00	00	00	00	00	00	00	
96-111	00	43	6F	70	79	72	69	67	68	74	20	28	63	29	20	[32]	COPYRIGHT
112-127	[30]	[30]	[31] ⁵	20	53	65	61	67	61	74	65	20	41	6C	6C	20	NOTICE
128-143	72	69	67	68	74	73	20	72	65	73	65	72	76	65	64	20	

- []¹ 03 means SCSI-3 (Ultra160) implemented.
04 means SCSI-4 (Ultra320) implemented (ST336732 and ST318432 models only)
- []² The drive can be changed between these two configurations:
02 means response data in SCSI-2/SCSI-3 format.
12 means the drive uses the hierarchical addressing mode to assign LUNs to logical units (default is 12).
- R# Four ASCII digits representing the last four digits of the product Firmware Release number. This information is also given in the Vital Product Data page C0h, together with servo RAM and ROM release numbers.
- S# Eight ASCII digits representing the eight digits of the product serial number.
- []³ Bytes 18 through 26 reflect model of drive. The table above shows the hex values for Model ST336752LW. Refer to the values below for the values of bytes 18 through 26 of you particular model:

ST336752LW	33	33	36	37	35	32	4C	57
ST336752LC	33	33	36	37	35	32	4C	43
ST318452LW	33	31	38	34	35	32	4C	57
ST318452LC	33	31	38	34	35	32	4C	43
ST336732LW	33	33	36	37	33	32	4C	57
ST336732LC	33	33	36	37	33	32	4C	43
ST318432LW	33	31	38	34	33	32	4C	57
ST318432LC	33	31	38	34	33	32	4C	43
- []⁵ Copyright Year - changes with actual year.

9.3.1 Inquiry Vital Product data

Instead of the standard Inquiry data shown in Table 7, the initiator can request several Vital Product Data pages by setting the Inquiry command EVPD bit to one. The *SCSI Interface Product Manual* lists the Vital Product Data pages and describes their formats. A separate Inquiry command must be sent to the drive for each Vital Product Data page the initiator wants the drive to send back.

9.3.2 Mode Sense data

The Mode Sense command provides a means for the drive to report its operating parameters to the initiator. The drive maintains four sets of Mode parameters, Default values, Saved values, Current values and Changeable values.

Default values are hard coded in the drive firmware that is stored in flash EPROM nonvolatile memory on the drive PCBA. Default values can be changed only by downloading a complete set of new firmware into the flash EPROM. An initiator can request and receive from the drive a list of default values and use those in a Mode Select command to set up new current and saved values, where the values are changeable.

Saved values are stored on the disk media using a Mode Select command. Only parameter values that are allowed to be changed can be changed by this method. See “Changeable values” defined below. Parameters in the saved values list that are not changeable by the Mode Select command get their values from the default values storage.

Current values are volatile values currently being used by the drive to control its operation. A Mode Select command can be used to change these values (only those that are changeable). Originally, they are installed from saved or default values after a power on reset, hard reset, or Bus Device Reset message.

Changeable values form a bit mask, stored in nonvolatile memory, that dictates which of the current values and saved values can be changed by a Mode Select command. A “one” allows a change to a corresponding bit; a “zero” allows no change. For example, in Table 8 refer to Mode page 01, in the row entitled “CHG”. These are hex numbers representing the changeable values for mode page 01. Note that bytes 04, 05, 06, and 07 are not changeable, because those fields are all zeros. If some changeable code had a hex value EF, that equates to the binary pattern 1110 1111. If there is a zero in any bit position in the field, it means that bit is not changeable. Bits 7, 6, 5, 3, 2, 1, and 0 are changeable, because those bits are all ones. Bit 4 is not changeable.

Though the drive always reports non-zero values in bytes 00 and 01, those particular bytes are never changeable.

The Changeable values list can only be changed by downloading new firmware into the flash EPROM.

On standard OEM drives the Saved values are taken from the default values list and stored into the saved values storage location on the media prior to shipping.

When a drive is powered up, it takes saved values from the media and stores them to the current values storage in volatile memory. It is not possible to change the current values (or the saved values) with a Mode Select command before the drive is up to speed and is “ready.” An attempt to do so results in a “Check Condition status being returned.

Note. Because there may be several different versions of drive control firmware in the total population of drives in the field, the Mode Sense values given in the following tables may not exactly match those of some drives.

Tables 8 and 9 list the values of the data bytes returned by ST336752 and ST318452 model drives in response to the Mode Sense command pages for SCSI Ultra160 implementation (see the *SCSI Interface Manual*).

Definitions:

DEF = Default value. Standard drives are shipped configured this way.

CHG= Changeable bits; indicates if current and saved values are changeable.

Note. Saved values for OEM drives are normally the same as the default values.

Table 8: ST336752 Mode sense data

Bytes	00	01	02	03	04	05	06	07	08	09	10	11	12	13	14	15	16	17	18	19	20	21	22	23	
Mode Sense Data	00	a6	00	10	00	00	00	08	04	45	dc	c9	00	00	02										
Mode Page	<-----Mode Page Headers and Parameter Data Bytes----->																								
01 DEF	81	0a	c0	0b	f0	00	00	00	05	00	ff	ff													
01 CHG	81	0a	ff	ff	00	00	00	00	ff	00	ff	ff													
02 DEF	82	0e	80	80	00	0a	00	00	00	00	00	00	00	00	00	00									
02 CHG	82	0e	ff	ff	00	00	00	00	00	00	00	00	87	00	00	00									
03 DEF	83	16	26	e8	00	00	00	33	00	00	01	e8	02	00	00	01	00	98	00	54	40	00	00	00	
03 CHG	83	16	00	00	00	00	00	00	00	00	00	00	00	00	00	00	00	00	00	00	00	00	00	00	
04 DEF	84	16	00	48	40	08	00	00	00	00	00	00	00	00	00	00	00	00	00	00	00	3a	94	00	00
04 CHG	84	16	00	00	00	00	00	00	00	00	00	00	00	00	00	00	00	00	00	00	00	00	00	00	00
07 DEF	87	0a	00	0b	f0	00	00	00	00	00	ff	ff													
07 CHG	87	0a	0f	ff	00	00	00	00	00	00	ff	ff													
08 DEF	88	12	14	00	ff	ff	00	00	ff	ff	ff	ff	80	14	00	00	00	00	00	00					
08 CHG	88	12	b5	00	00	00	ff	ff	ff	ff	00	00	a0[1]	ff	00	00	00	00	00	00					
0A DEF	8a	0a	02	00	00	00	00	00	00	00	03	84													
0A CHG	8a	0a	03	f1	00	00	00	00	00	00	00	00													
1A DEF	9a	0a	00	03	00	00	00	01	00	00	00	04													
1A CHG	9a	0a	00	03	00	00	00	00	00	00	00	00													
1C DEF	9c	0a	10	00	00	00	00	00	00	00	00	01													
1C CHG	9c	0a	9d	0f	ff	ff	ff	ff	ff	ff	ff	ff													
00 DEF	80	06	00	00	0f	00	00	00																	
00 CHG	80	06	f7	40	0f	00	00	00																	
Read capacity data																									
	04	45	dc	c8	00	00	02	00																	

[1] Though byte 12, bit 7 (A0) is shown as changeable, the FSW function governed by that bit is not implemented by this drive.

Table 9: ST318452 Mode sense data

Bytes	00	01	02	03	04	05	06	07	08	09	10	11	12	13	14	15	16	17	18	19	20	21	22	23
Mode Sense Data	00	a6	00	10	00	00	00	08	02	22	ee	56	00	00	02	00								
Mode Page	<-----Mode Page Headers and Parameter Data Bytes----->																							
01 DEF	81	0a	c0	0b	f0	00	00	00	05	00	ff	ff												
01 CHG	81	0a	ff	ff	00	00	00	00	ff	00	ff	ff												
02 DEF	82	0e	80	80	00	0a	00	00	00	00	00	00	00	00	00	00								
02 CHG	82	0e	ff	ff	00	00	00	00	00	00	00	00	87	00	00	00								
03 DEF	83	16	13	74	00	00	00	19	00	00	01	e8	02	00	00	01	00	98	00	54	40	00	00	00
03 CHG	83	16	00	00	00	00	00	00	00	00	00	00	00	00	00	00	00	00	00	00	00	00	00	00
04 DEF	84	16	00	48	40	04	00	00	00	00	00	00	00	00	00	00	00	00	00	00	3a	94	00	00
04 CHG	84	16	00	00	00	00	00	00	00	00	00	00	00	00	00	00	00	00	00	00	00	00	00	00
07 DEF	87	0a	00	0b	f0	00	00	00	00	00	ff	ff												
07 CHG	87	0a	0f	ff	00	00	00	00	00	00	ff	ff												
08 DEF	88	12	14	00	ff	ff	00	00	ff	ff	ff	ff	80	14	00	00	00	00	00	00				
08 CHG	88	12	b5	00	00	00	ff	ff	ff	ff	00	00	a0[1]	ff	00	00	00	00	00	00				
0A DEF	8a	0a	02	00	00	00	00	00	00	00	01	f4												
0A CHG	8a	0a	03	f1	00	00	00	00	00	00	00	00												
1A DEF	9a	0a	00	03	00	00	00	01	00	00	00	04												
1A CHG	9a	0a	00	03	00	00	00	00	00	00	00	00												
1C DEF	9c	0a	10	00	00	00	00	00	00	00	00	01												
1C CHG	9c	0a	9d	0f	ff	ff	ff	ff	ff	ff	ff	ff												
00 DEF	80	06	00	00	0f	00	00	00																
00 CHG	80	06	f7	40	0f	00	00	00																
Read capacity data	02	22	ee	55	00	00	02	00																

[1] Though byte 12, bit 7 (A0) is shown as changeable, the FSW function governed by that bit is not implemented by this drive.

Tables 10 and 11 list the values of the data bytes returned by ST336732 and ST318432 model drives in response to the Mode Sense command pages for SCSI Ultra320 implementation (see the *SCSI Interface Manual*).

Definitions:

DEF = Default value. Standard drives are shipped configured this way.

CHG= Changeable bits; indicates if current and saved values are changeable.

Note. Saved values for OEM drives are normally the same as the default values.

Table 10: ST336732 Mode sense data

Bytes	00	01	02	03	04	05	06	07	08	09	10	11	12	13	14	15	16	17	18	19	20	21	22	23	
Mode Sense Data	00	a6	00	10	00	00	10	08	04	45	dc	c9	00	00	02										
Mode Page	<-----Mode Page Headers and Parameter Data Bytes----->																								
01 DEF	81	0a	c0	0b	f0	00	00	00	05	00	ff	ff													
01 CHG	81	0a	ff	ff	00	00	00	00	ff	00	ff	ff													
02 DEF	82	0e	80	80	00	0a	00	00	00	00	00	00	00	00	00	00									
02 CHG	82	0e	ff	ff	00	00	00	00	00	00	00	00	87	00	00	00									
03 DEF	83	16	26	e8	00	00	00	33	00	00	01	e8	02	00	00	01	00	98	00	54	40	00	00	00	
03 CHG	83	16	00	00	00	00	00	00	00	00	00	00	00	00	00	00	00	00	00	00	00	00	00	00	
04 DEF	84	16	00	48	40	08	00	00	00	00	00	00	00	00	00	00	00	00	00	00	00	3a	94	00	00
04 CHG	84	16	00	00	00	00	00	00	00	00	00	00	00	00	00	00	00	00	00	00	00	00	00	00	00
07 DEF	87	0a	00	0b	f0	00	00	00	00	00	ff	ff													
07 CHG	87	0a	0f	ff	00	00	00	00	00	00	ff	ff													
08 DEF	88	12	14	00	ff	ff	00	00	ff	ff	ff	ff	00	1c	00	00	00	00	00	00					
08 CHG	88	12	b5	00	00	00	ff	ff	ff	ff	00	00	a0[1]	ff	00	00	00	00	00	00					
0A DEF	8a	0a	02	00	00	00	00	00	00	00	03	84													
0A CHG	8a	0a	03	f1	00	00	00	00	00	00	00	00													
19 DEF	19	06	00	01	ff	ff	00	00																	
19 CHG	19	06	00	00	ff	ff	00	00																	
1A DEF	9a	0a	00	03	00	00	00	01	00	00	00	04													
1A CHG	9a	0a	00	03	00	00	00	00	00	00	00	00													
1C DEF	9c	0a	10	00	00	00	00	00	00	00	00	01													
1C CHG	9c	0a	9d	0f	ff	ff	ff	ff	ff	ff	ff	ff													
00 DEF	80	06	00	00	0f	00	00	00																	
00 CHG	80	06	f7	40	0f	00	00	00																	
Read capacity data																									
	04	45	dc	c8	00	00	02	00																	

[1] Though byte 12, bit 7 (A0) is shown as changeable, the FSW function governed by that bit is not implemented by this drive.

Table 11: ST318432 Mode sense data

Bytes	00	01	02	03	04	05	06	07	08	09	10	11	12	13	14	15	16	17	18	19	20	21	22	23
Mode Sense Data	00	a6	00	10	00	00	00	08	02	22	ee	56	00	00	02	00								
Mode Page	<-----Mode Page Headers and Parameter Data Bytes----->																							
01 DEF	81	0a	c0	0b	f0	00	00	00	05	00	ff	ff												
01 CHG	81	0a	ff	ff	00	00	00	00	ff	00	ff	ff												
02 DEF	82	0e	80	80	00	0a	00	00	00	00	00	00	00	00	00									
02 CHG	82	0e	ff	ff	00	00	00	00	00	00	00	00	87	00	00	00								
03 DEF	83	16	13	74	00	00	00	19	00	00	01	e8	02	00	00	01	00	98	00	54	40	00	00	00
03 CHG	83	16	00	00	00	00	00	00	00	00	00	00	00	00	00	00	00	00	00	00	00	00	00	00
04 DEF	84	16	00	48	40	04	00	00	00	00	00	00	00	00	00	00	00	00	00	00	3a	94	00	00
04 CHG	84	16	00	00	00	00	00	00	00	00	00	00	00	00	00	00	00	00	00	00	00	00	00	00
07 DEF	87	0a	00	0b	f0	00	00	00	00	00	ff	ff												
07 CHG	87	0a	0f	ff	00	00	00	00	00	00	ff	ff												
08 DEF	88	12	14	00	ff	ff	00	00	ff	ff	ff	ff	80	14	00	00	00	00	00	00				
08 CHG	88	12	b5	00	00	00	ff	ff	ff	ff	00	00	a0[1]	ff	00	00	00	00	00	00				
0A DEF	8a	0a	02	00	00	00	00	00	00	00	01	f4												
0A CHG	8a	0a	03	f1	00	00	00	00	00	00	00	00												
19 DEF	19	06	00	01	ff	ff	00	00																
19 CHG	19	06	00	00	ff	ff	00	00																
1A DEF	9a	0a	00	03	00	00	00	01	00	00	00	04												
1A CHG	9a	0a	00	03	00	00	00	00	00	00	00	00												
1C DEF	9c	0a	10	00	00	00	00	00	00	00	00	01												
1C CHG	9c	0a	9d	0f	ff	ff	ff	ff	ff	ff	ff	ff												
00 DEF	80	06	00	00	0f	00	00	00																
00 CHG	80	06	f7	40	0f	00	00	00																
Read capacity data	02	22	ee	55	00	00	02	00																

[1] Though byte 12, bit 7 (A0) is shown as changeable, the FSW function governed by that bit is not implemented by this drive.

9.4 SCSI bus conditions and miscellaneous features supported

Asynchronous SCSI bus conditions supported by the drive are listed below. These conditions cause the SCSI device to perform certain actions and can alter the SCSI bus phase sequence. Other miscellaneous operating features supported are also listed here. Refer to the *SCSI Interface Product Manual* for details.

Table 12: SCSI bus conditions and other miscellaneous features

Condition/feature supported by:

Supported	Conditions or feature
Y	Adaptive Caching
Y	Arbitrating System
Y	Asynchronous Data Transfer
N	Asynchronous Event Notification
Y	Attention Condition
N	Auto Contingent Allegiance Condition
Y	Contingent Allegiance Condition
Y	Deferred Error Handling
Y	Disconnect/Reconnect
N	High voltage differential (HVD) interface available
Y	Low voltage differential (LVD) interface available
Y	Parameter Rounding (controlled by the Round bit in Mode Select page 0)
Y	Queue tagging (up to 64 Queue tags supported)
Y	Reporting actual retry count in Extended Sense bytes 15, 16 and 17.
Y	Reset Condition
Y	Segmented Caching
Y	Synchronous Data Transfer
N	Zero Latency Read

Supported	Status
Y	Good
Y	Check Condition
Y	Condition Met/Good
Y	Busy
Y	Intermediate/Good
Y	Intermediate/Condition Met/Good
Y	Reservation Conflict
Y	Queue Full
N	ACA Active

9.5 Synchronous data transfer

9.5.1 Synchronous data transfer periods supported

The data transfer period to be used by the drive and the initiator is established by an exchange of messages during the Message Phase of operation. See the section on message protocol in the *SCSI Interface Product Manual*, part number 75789509. In the following tables, M is the synchronous period value (in the transfer rate negotiation message) that represents the associated transfer period and transfer rate values.

Table 13 lists the synchronous data transfer periods supported by the drive in DT DATA phase. DT DATA phase is only allowed when using the LVD interface.

Table 13: Synchronous DT DATA transfer periods

M (decimal)	Transfer period (nanoseconds)	Transfer rate (megatransfers/second)	Transfer rate (MBytes/sec) on wide bus
8	6.25	160.0 ¹	320.0 ¹
9	12.5	80.0	160.0
10	25	40.0	80.0
12	50	20.0	40.0
25	100	10.0	20.0

1. This transfer rate is only supported on drives which support the Ultra320 interface (ST336732 and ST318432 models).

Table 14 lists the synchronous data transfer periods supported by the drive in ST DATA phase. ST DATA phase is allowed with either LVD or SE interface except as noted.

Table 14: Synchronous ST DATA transfer periods

M (decimal)	Transfer period (nanoseconds)	Transfer rate (megatransfers/second)
10	25	40.0 ¹
12	50	20.0
25	100	10.0
50	200	5.0

1. This transfer rate is only allowed when using the LVD interface.

9.5.2 REQ/ACK offset

Cheetah X15 36LP family drives support REQ/ACK offset values from 7 to 63 (3Fh). Offsets of 1 through 6 are negotiated to 0 (asynchronous transfer).

9.6 Physical interface

This section describes the connectors, cables, signals, terminators and bus timing of the DC and SCSI I/O interface. See Section 9.8 and Section 9.9 for additional terminator information.

Figures 18 and 19 show the locations of the DC power connector, SCSI interface connector, drive select headers, and option select headers.

Details of the physical, electrical and logical characteristics are given in sections following, while the SCSI operational aspects of Seagate drive interfaces are given in the *SCSI Interface Product Manual*.

9.6.1 DC cable and connector

ST336752LW and ST318452LW drives receive DC power through a 4 pin connector (see Figure 20 for pin assignment) mounted at the rear of the main PCBA. Recommended part numbers of the mating connector are listed below, but equivalent parts may be used.

Type of cable	Connector	Contacts (20-14 AWG)
14 AWG	MP 1-480424-0	AMP 60619-4 (Loose Piece) AMP 61117-4 (Strip)

LC model drives receive power through the 80-pin I/O connector. See Tables 18 and 19.

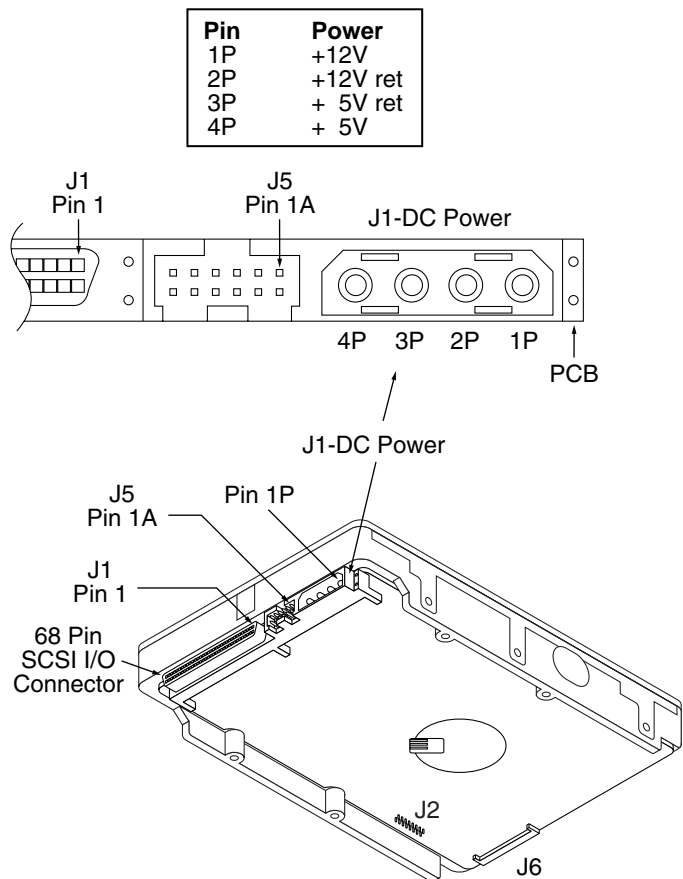

Figure 18. LW model drive physical interface (68-pin J1 SCSI I/O connector)

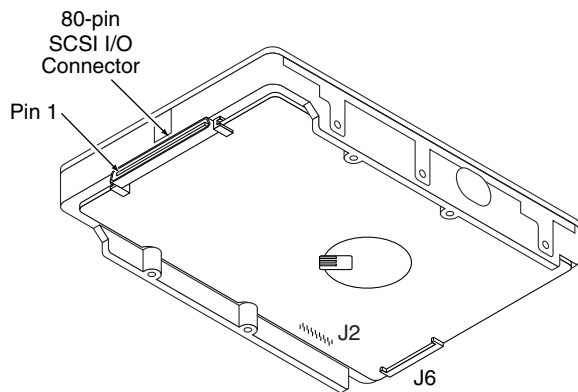

Figure 19. LC model drive physical interface (80-pin J1 SCSI I/O connector)

9.6.2 SCSI interface physical description

The drives documented in this manual support single-ended and low voltage differential physical interconnects (hereafter referred to as SE and LVD, respectively) as described in the SPI-4 standard. These drives implement driver and receiver circuits that can operate either SE or LVD. However, they cannot switch dynamically between SE and LVD operation.

- ST336752 and ST318452 models support the physical interface requirements of the SPI-4 standard and operate compatibly at the interface with devices that support earlier SCSI-2 and SCSI-3 standards. It should be noted that this is only true if the systems engineering has been correctly done, and if earlier SCSI-2 and SCSI-3 devices respond in an acceptable manner (per applicable SCSI Standards) to reject newer Ultra160 protocol extensions that they don't support.
- ST336732 and ST318432 models support the physical interface requirements of the SPI-4 standard and operate compatibly at the interface with devices that support earlier SCSI-2 and SCSI-3 standards. It should be noted that this is only true if the systems engineering has been correctly done, and if earlier SCSI-2 and SCSI-3 devices respond in an acceptable manner (per applicable SCSI Standards) to reject newer Ultra320 protocol extensions that they don't support.

The drives typically operate on a daisy-chain interface in which other SCSI devices are also operating. Devices on the daisy chain must all operate in the same mode, either SE or LVD, but not a mixture of these. On the interface daisy chain, all signals are common between all devices on the chain, or bus, as it is also called. This daisy chain of SCSI devices must be terminated at both ends with the proper impedance in order to operate correctly. Do not terminate intermediate SCSI devices. In some cases, the SCSI devices at each end have onboard termination circuits that can be enabled by installation of a jumper plug (**TE**) on the device. These termination circuits receive power from either a source internal to the device, or from a line in the interface cable specifically powered for that purpose. LC and LW model drives do not have onboard termination circuits. Some type of external termination circuits must be provided for these drives by the end user or designers of the equipment into which the drives will be integrated. See the SPI-4 standard for the maximum number of devices that can successfully operate at various interface transfer rates on SE and LVD daisy chains.

LC model drives plug into PCBA or bulkhead connectors in the host. They may be connected in a daisy-chain by the host backplane wiring or PCBA circuit runs that have adequate DC current carrying capacity to support the number of drives plugged into the PCBA or bulkhead connectors. A single 80-pin I/O connector cable cannot support the DC current needs of several drives, so no daisy chain cables beyond the bulkhead connectors should be used. A single drive connected via a cable to a host 80-pin I/O connector is not recommended.

Table 15 shows the interface transfer rates supported by the various drive models defined in this manual.

Table 15: Interface transfer rates supported

Interface type/ drive models		Maximum transfer rate						
		Asynchronous	Fast-5	Fast-10	Fast-20 (Ultra)	Fast-40 (Ultra2)	Fast-80 (Ultra160)	Fast-160 (Ultra320)
SE	ST336752LW ST336752LC ST318452LW ST318452LC	yes	yes	yes	yes	no	no	no
LVD	ST336752LW ST336752LC ST318452LW ST318452LC	yes	yes	yes	yes	yes	yes	no
SE	ST336732LW ST336732LC ST318432LW ST318432LC	yes	yes	yes	yes	no	no	no
LVD	ST336732LW ST336732LC ST318432LW ST318432LC	yes	yes	yes	yes	yes	yes	yes

9.6.3 SCSI interface cable requirements

The characteristics of cables used to connect parallel interface drives are discussed in the ANSI standards referenced in this section.

9.6.3.1 Cable requirements

The characteristics of cables used to connect Ultra160 and Ultra320 SCSI parallel interface devices are discussed in detail in section 6 of the SPI-4 standard. The cable characteristics that must be considered when interconnecting the drives described in this manual in a SCSI parallel, daisy-chain interconnected system are:

- characteristic impedance (see SPI-4 sections 6.3.3, 6.3.4, and 6.3.5)
- propagation delay (see SPI-4 sections 6.3.6 and 6.3.7)
- cumulative length (see SPI-4 sections 6.6 and 6.8)
- stub length (see SPI-4 sections 6.6 and 6.9)
- device spacing (see SPI-4 sections 6.6 and 6.9)

To minimize discontinuances and signal reflections, cables of different impedances should not be used on the same bus. Implementations may require trade-offs in shielding effectiveness, cable length, number of loads and spacing, transfer rates, and cost to achieve satisfactory system operation. If shielded and unshielded cables are mixed within the same SCSI bus, the effect of impedance mismatch must be carefully considered. Proper impedance matching is especially important in order to maintain adequate margin at Fast-20, Fast-40, Fast-80, and Fast-160 SCSI transfer rates.

Note. For LVD operation, twisted pair cables are recommended. For LVD Fast-40 operation, twisted pair cables are *strongly* recommended. For Fast-80 or Fast-160 operation, twisted pair cables are *required*.

All LC model drives:

The 80-pin connector option is intended for use on drives that plug directly into backplane connector in the host equipment. In such installations, all backplane wiring segments are subject to the electromagnetic concepts presented in section 6 of the SPI-4 standard. For LC model drives, installations with connectors on cables are not recommended.

9.6.4 Mating connectors

Part numbers for the different type connectors that mate with the various Cheetah X15 36LP I/O connectors are given in the sections following.

9.6.4.1 Mating connectors for LW model drives

The nonshielded cable connector shall be a 68 conductor connector consisting of two rows of 34 male contacts with adjacent contacts 0.050 inch (1.27 mm) apart.

Recommended mating flat cable connector part numbers are:

Amp Model 786096-7	Female, 68-pin, panel mount
Amp Model 786090-7	Female, 68-pin, cable mount
Amp Model 749925-5	(50 mil conductor centers, 28 or 30 AWG wire) Use two, 34 conductor, 50 mil center flat cable with this connector. This type connector can only be used on cable ends. [1]
Amp Model 88-5870-294-5	W/O Strain Relief (25 mil conductor centers, 30 AWG wire). Use either on cable ends or in cable middle section for daisy-chain installations [1].
Amp Model 1-480420-0	Power connector 4 circuit housing
Berg 69307-012	12-position, 2 x 6, 2 mm receptacle housing

[1] See Figure 20.

The drive device connector is a nonshielded 68 conductor connector consisting of two rows of 34 female pins with adjacent pins 50 mils apart. The connector is keyed by means of its shape (see Figure 21).

9.6.4.2 Mating connectors for LC model drives

The nonshielded connector shall be an 80-conductor connector consisting of two rows of 40 contacts with adjacent contacts 50 (1.27 mm) mils apart (see Figure 22). I/O connection using a cable is not recommended. The length and size of the host equipment DC power carrying conductors from the DC power source to the host equipment 80-pin disk drive interface connector(s) should be strictly designed according to proper power transmission design concepts. No possibility for the equipment user to attach an 80-pin cable/connector should be allowed, since the length of the DC power carrying conductors could not be controlled and therefore could become too long for safe power transmission to the drive. Daisy-chain 80-conductor cables should especially not be allowed, since the power-carrying conductors on the 80-conductor interface were not intended to support a series of drives.

To insure that both drive connector and host equipment mating connector mate properly, both drive connector and host equipment mating connector must meet the provisions of "SFF-8451 Specification for SCA-2 Unshielded Connections." See www.sffcommittee.org to obtain this specification.

Recommended mating 80-position PCBA mount connectors:

Straight-in connector	Hot plug version (with ground guide-pin)	
Seagate P/N: 77678703		
Amp US P/N: 2-557103-1	787311-1	with polarization
or 94-0680-02-1		
Amp US P/N: 2-557103-2	787311-2	without polarization
or 94-0680-02-2		
Amp Japan P/N: 5-175475-9		

Right-angle to PCBA connectors

Seagate P/N:	77678559
Amp US P/N:	2-557101-1
Amp Japan P/N:	5-175474-9

For additional information call Amp FAX service at 1-800-522-6752.

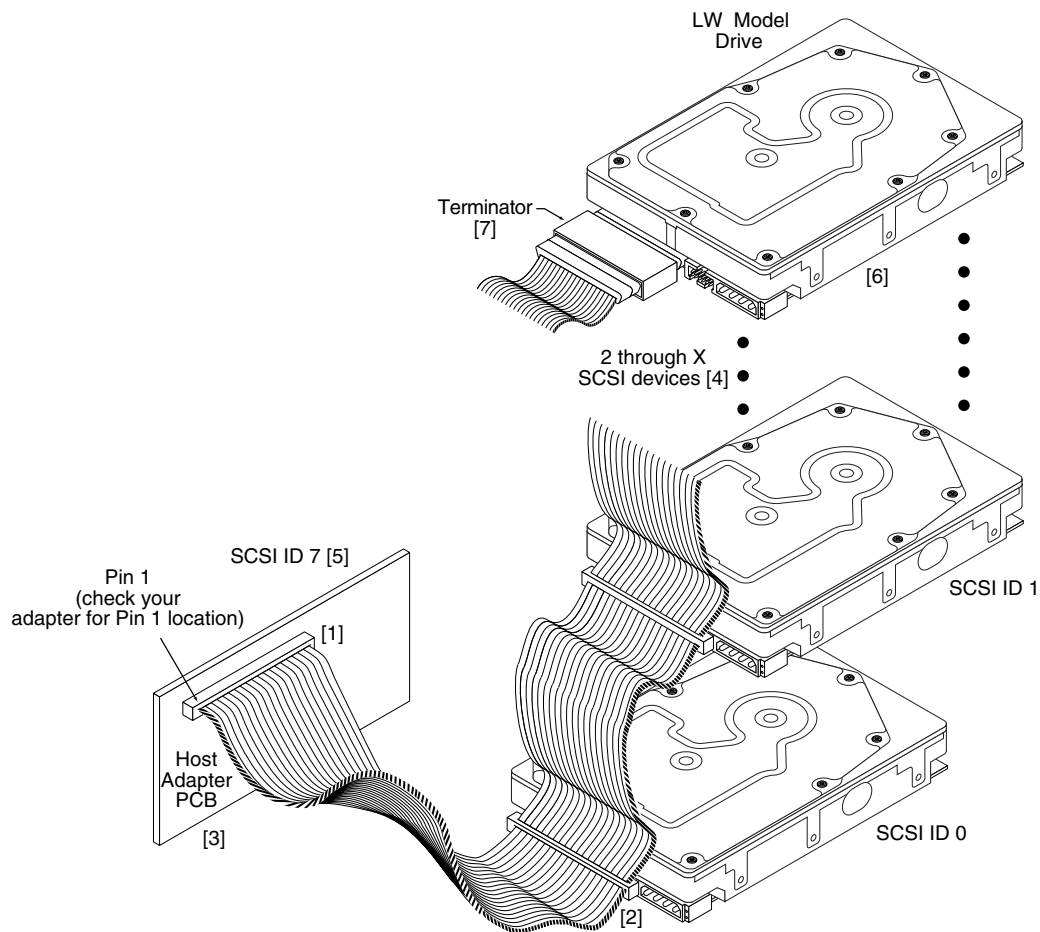

- [1] Closed end type 68-pin connector used. Terminators enabled.
- [2] Open end type (in-line application) connector used.
- [3] Host need not be on the end of the daisy-chain. Another device can be on the end with the terminator, the host having no terminator.
- [4] Total interface cable length must not exceed that specified in the SPI-4 standard (including host adapter/initiator). The cable length restriction limits the total number of devices allowed.
- [5] SCSI ID7 has highest arbitration priority, then ID15 to ID8 (ID 8 has the very lowest priority).
- [6] Last drive on the daisy chain.
- [7] Open-end type 68-pin connector used. If end device, use external terminator and closed-end type 68-pin connector.

Figure 20. SCSI daisy chain interface cabling for LW drives

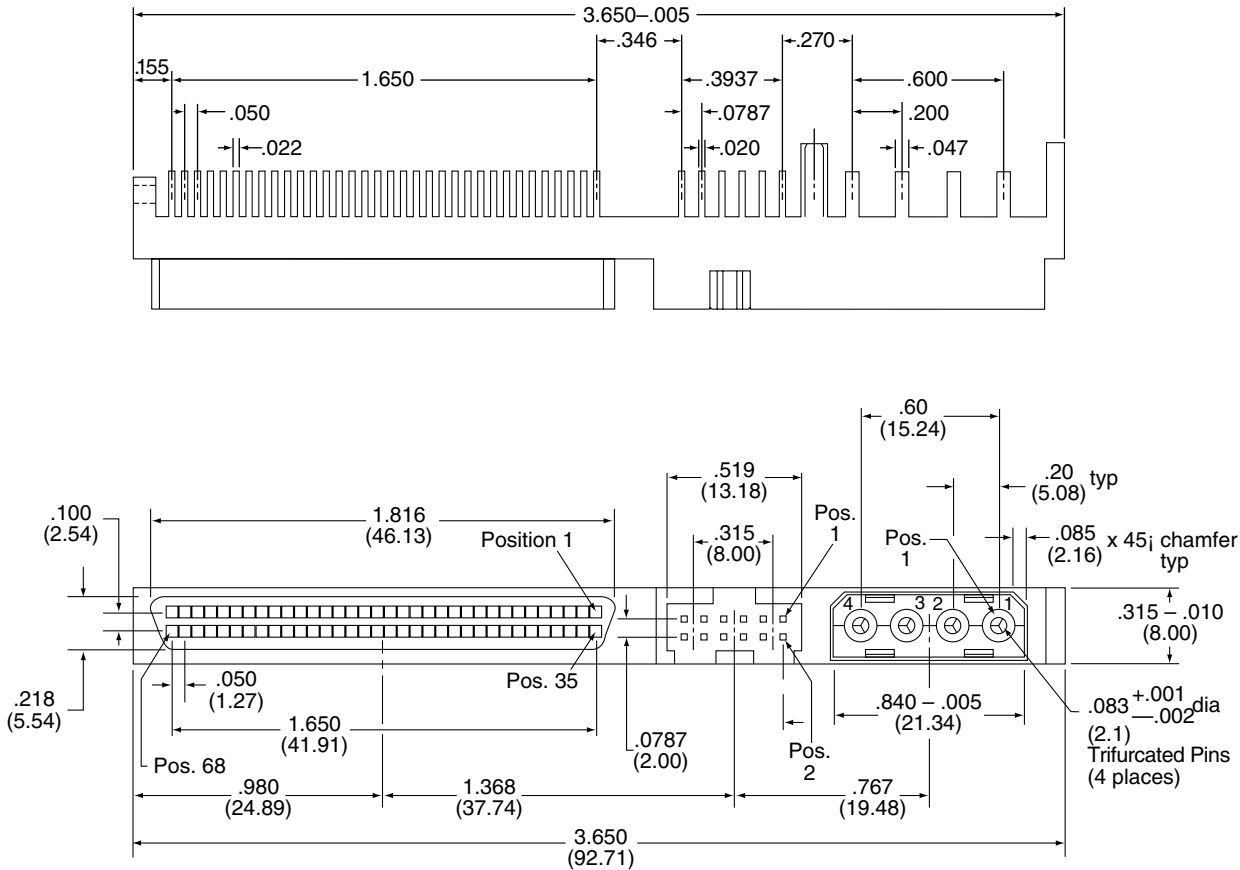

Figure 21. Nonshielded 68 pin SCSI device connector used on LW drives

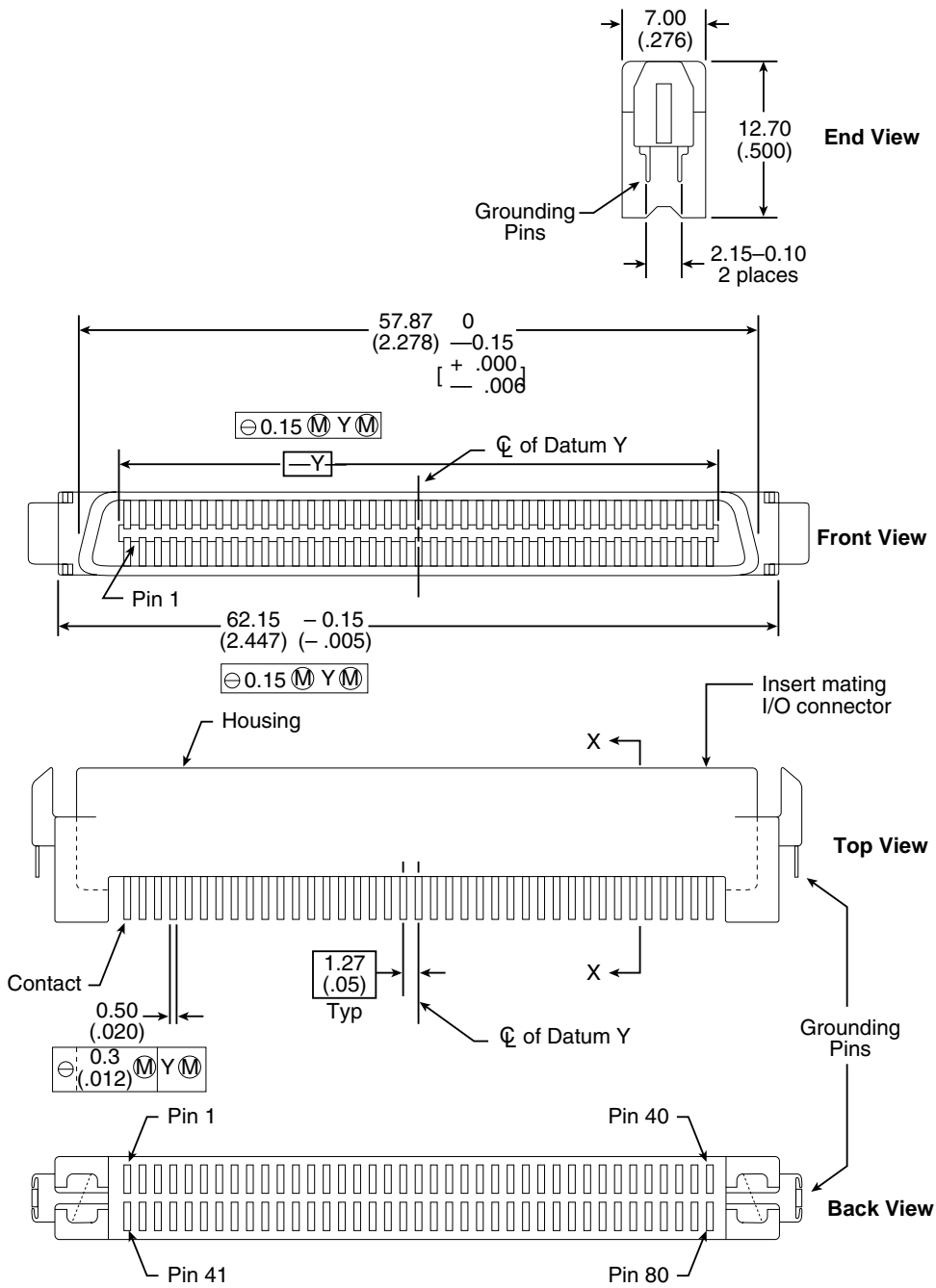

Figure 22. Nonshielded 80 pin SCSI "SCA-2" connector, used on LC drives

Table 16: LW 68-conductor single-ended (SE) P cable signal/pin assignments [11]

Note. A minus sign preceding a signal name indicates that signal is active low.

Signal name [1]	Connector contact number [3]	Cable conductor number [2]		Connector contact number [3]	Signal name [1]
GND	1	1	2	35	-DB12
GND	2	3	4	36	-DB13
GND	3	5	6	37	-DB14
GND	4	7	8	38	-DB15
GND	5	9	10	39	-DBP1
GND	6	11	12	40	-DB0
GND	7	13	14	41	-DB1
GND	8	15	16	42	-DB2
GND	9	17	18	43	-DB3
GND	10	19	20	44	-DB4
GND	11	21	22	45	-DB5
GND	12	23	24	46	-DB6
GND	13	25	26	47	-DB7
GND	14	27	28	48	-DBP
GND	15	29	30	49	GND
GND	16	31	32	50	GND
TermPwr	17	33	34	51	TermPwr
TermPwr	18	35	36	52	TermPwr
Reserved	19	37	38	53	Reserved
GND	20	39	40	54	GND
GND	21	41	42	55	-ATN
GND	22	43	44	56	GND
GND	23	45	46	57	-BSY
GND	24	47	48	58	-ACK
GND	25	49	50	59	-RST
GND	26	51	52	60	-MSG
GND	27	53	54	61	-SEL
GND	28	55	56	62	-C/D
GND	29	57	58	63	-REQ
GND	30	59	60	64	-I/O
GND	31	61	62	65	-DB8
GND	32	63	64	66	-DB9
GND	33	65	66	67	-DB10
GND	34	67	68	68	-DB11

Notes []: See page following Table 19.

Table 17: LW 68-conductor LVD P cable signal/pin assignments [11]

Note. A minus sign preceding a signal name indicates that signal is active low.

Signal name [1]	Connector contact number [3]	Cable conductor number [2]		Connector contact number [3]	Signal name [1]
+DB12	1	1	2	35	-DB12
+DB13	2	3	4	36	-DB13
+DB14	3	5	6	37	-DB14
+DB15	4	7	8	38	-DB15
+DBP1	5	9	10	39	-DBP1
+DB0	6	11	12	40	-DB0
+DB1	7	13	14	41	-DB1
+DB2	8	15	16	42	-DB2
+DB3	9	17	18	43	-DB3
+DB4	10	19	20	44	-DB4
+DB5	11	21	22	45	-DB5
+DB6	12	23	24	46	-DB6
+DB7	13	25	26	47	-DB7
+DBP	14	27	28	48	-DBP
Ground	15	29	30	49	Ground
DIFFSNS [8]	16	31	32	50	Ground
TermPwr	17	33	34	51	TermPwr
TermPwr	18	35	36	52	TermPwr
Reserved	19	37	38	53	Reserved
Ground	20	39	40	54	Ground
+ATN	21	41	42	55	-ATN
Ground	22	43	44	56	Ground
+BSY	23	45	46	57	-BSY
+ACK	24	47	48	58	-ACK
+RST	25	49	50	59	-RST
+MSG	26	51	52	60	-MSG
+SEL	27	53	54	61	-SEL
+C/D	28	55	56	62	-C/D
+REQ	29	57	58	63	-REQ
+I/O	30	59	60	64	-I/O
+DB8	31	61	62	65	-DB8
+DB9	32	63	64	66	-DB9
+DB10	33	65	66	67	-DB10
+DB11	34	67	68	68	-DB11

Notes []: See page following Table 19.

Table 18: LC 80-pin single-ended (SE) I/O connector pin assignments [11]

Note. A minus sign preceding a signal name indicates that signal is active low.

Signal name [1]	Connector contact number [3]	Signal number [3]	Contact name[1]
12 V CHARGE	1	41	12 V GND
12 V	2	42	12 V GND
12 V	3	43	12 V GND
12 V	4	44	MATED 1 [12]
NC [10]	5	45	NC [10]
NC [10]	6	46	DIFFSNS [8]
-DB11	7	47	GND
-DB10	8	48	GND
-DB9	9	49	GND
-DB8	10	50	GND
-I/O	11	51	GND
-REQ	12	52	GND
-C/D	13	53	GND
-SEL	14	54	GND
-MSG	15	55	GND
-RST	16	56	GND
-ACK	17	57	GND
-BSY	18	58	GND
-ATN	19	59	GND
-DBP	20	60	GND
-DB7	21	61	GND
-DB6	22	62	GND
-DB5	23	63	GND
-DB4	24	64	GND
-DB3	25	65	GND
-DB2	26	66	GND
-DB1	27	67	GND
-DB0	28	68	GND
-DP1	29	69	GND
-DB15	30	70	GND
-DB14	31	71	GND
-DB13	32	72	GND
-DB12	33	73	GND
+5 V	34	74	MATED 2
+5 V	35	75	5 V GND
+5 V	36	76	5 V GND
NC [10]	37	77	ACTIVE LED OUT [4] [9]
RMT-START [5] [9] [12]	38	78	DLYD-START [6] [9] [12]
SCSI ID (0) [7] [9] [12]	39	79	SCSI ID (1) [7] [9] [12]
SCSI ID (2) [7] [9] [12]	40	80	SCSI ID (3) [7] [9] [12]

Notes []: See page following Table 19.

Table 19: LC 80-pin single-ended (LVD) I/O connector pin assignments [11]

Note. A minus sign preceding a signal name indicates that signal is active low.

Signal name [1]	Connector contact number [3]	Signal number [3]	Contact name[1]
12 V CHARGE	1	41	12 V GND
12 V	2	42	12 V GND
12 V	3	43	12 V GND
12 V	4	44	MATED 1 [12]
NC [10]	5	45	NC [10]
NC [10]	6	46	DIFFSNS [8]
-DB11	7	47	+DB11
-DB10	8	48	+DB10
-DB9	9	49	+DB9
-DB8	10	50	+DB8
-I/O	11	51	+I/O
-REQ	12	52	+REQ
-C/D	13	53	+C/D
-SEL	14	54	+SEL
-MSG	15	55	+MSG
-RST	16	56	+RST
-ACK	17	57	+ACK
-BSY	18	58	+BSY
-ATN	19	59	+ATN
-DBP	20	60	+DBP0
-DB7	21	61	+DB7
-DB6	22	62	+DB6
-DB5	23	63	+DB5
-DB4	24	64	+DB4
-DB3	25	65	+DB3
-DB2	26	66	+DB2
-DB1	27	67	+DB1
-DB0	28	68	+DB0
-DBP1	29	69	+DP1
-DB15	30	70	+DB15
-DB14	31	71	+DB14
-DB13	32	72	+DB13
-DB12	33	73	+DB12
+5 V	34	74	MATED 2
+5 V	35	75	5 V GND
+5 V CHARGE	36	76	5 V GND
NC [10]	37	77	ACTIVE LED OUT [4] [9]
RMT_START [5] [9] [12]	38	78	DLYD_START [6] [9] [12]
SCSI ID (0) [7] [9] [12]	39	79	SCSI ID (1) [7] [9] [12]
SCSI ID (2) [7] [9] [12]	40	80	SCSI ID (3) [7] [9] [12]

Notes []: See page following this table.

Notes [] for Tables 16 through 19.

- [1] See Section 9.6.4.1 for detailed electrical characteristics of these signals.
- [2] The conductor number refers to the conductor position when using 0.025-inch (0.635 mm) centerline flat ribbon cable. Other cables types may be used to implement equivalent contact assignments.
- [3] Connector contacts are on 0.050 inch (1.27 mm) centers.
- [4] Front panel LED signal; indicates drive activity for host front panel hard drive activity indicator.
- [5] Asserted by host to enable Motor Start option (enables starting motor via SCSI bus command).
- [6] Asserted by host to enable Delayed Motor Start option (motor starts at power on or after a delay of 12 seconds times drive ID). This and [3] above are mutually exclusive options.
- [7] Binary code on A3, A2, A1 and A0 asserted by host to set up SCSI bus ID in drive.
- [8] GND provides a means for differential devices to detect the presence of a single ended device on the bus. Drive will not operate I/O bus at Ultra2 or faster SCSI data rates if this is grounded.
- [9] Signals [4] through [7] are used in place of installing jumpers and cables on option select connectors J2 and J6. See Section 8.1.1 notes.
- [10] "NC" means no connection.
- [11] 8 bit devices which are connected to the 16 data bit LVD I/O shall leave the following signals open: –DB8, –DB9, –DB10, –DB11, –DB12, –DB13, –DB14, –DB15, and –DBP1.
8 bit devices which are connected to the 16 data bit single-ended (SE) I/O shall have the following signals open: DB8, –DB9, –DB10, –DB11, –DB12, –DB13, –DB14, –DB15, and –DBP1.
All other signals should be connected as shown.
- [12] Pins 38, 39, 40, 44, 78, 79, and 80 are option select pins and are tied high by the drive circuitry. The preferred electrical connection at the backplane is either open or grounded (open for the '1' setting, grounded for the '0' setting). Alternatively, these pins may be driven by a 3.3V logic device, pulled up to 3.3V through a pull-up resistor (recommended size of 10K ohm), or grounded through some other means.

9.7 Electrical description

Cheetah X15 36LP drives are multimode devices. That is, their I/O circuits can operate as either single-ended or low voltage differential drivers/receivers (selectable using the I/O "DIFFSENS" line).

See the SPI-4 standard for detailed electrical specifications.

9.7.1 Multimode—SE and LVD alternatives

When the interface "DIFFSENS" line is between -0.35 V and +0.5 V, the drive interface circuits operate single-ended and up to and including 20 M transfers/s (Fast-20 or Ultra SCSI). When "DIFFSENS" is between +0.7 V and +1.9 V, the drive interface circuits operate low voltage differential and up to and including 160 M transfers/s or less (Fast-160 or Ultra320 SCSI).

This multimode design does not allow dynamically changing transmission modes. Drives must operate only in the mode for which the installation and interface cabling is designed. Multimode I/O circuits used by these drives do not operate at high voltage differential levels and should never be exposed to high voltage differential environments unless the common mode voltages in the environment are controlled to safe levels for single-ended and low voltage differential devices (see the SPI-4 standard).

LC and LW model drives do not have onboard terminators. Termination of the I/O lines must be provided for by the Host equipment designers or end users.

LVD Output characteristics

Each differential signal driven by LVD interface drivers shall have the following output characteristics when measured at the disc drive connector:

Steady state Low level output differential voltage = 0.260 V = < V_s = < 0.640 V (signal negation/logic 0)

Steady state High level output differential voltage = 0.270 V = < V_s = < 0.780 V (signal assertion/logic 1)

LVD Input characteristics

Each differential signal received by LVD interface receiver circuits shall have the following input characteristics when measured at the disk drive connector:

Steady state Low level input differential voltage = $0.030\text{ V} < V_{IN} < 3.6\text{ V}$ (signal negation/logic 0)
 Steady state High level input differential voltage* = $-3.6\text{ V} < V_s < -0.030\text{ V}$ (signal assertion/logic 1)
 Differential voltage = $\pm 0.030\text{ V}$ minimum with common-mode voltage range $0.700\text{ V} < V_{cm} < 1.800\text{ V}$.
 (X3T10/1142D revision 20b Section A.3.1)

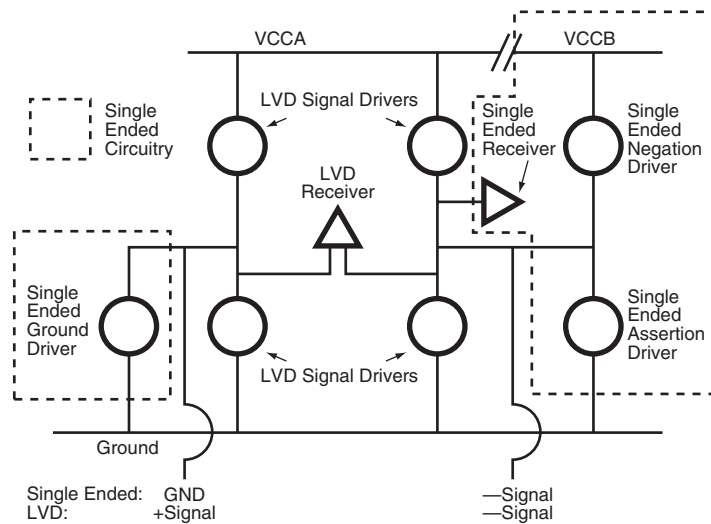

Figure 23. Typical SE-LVD alternative transmitter receiver circuits

9.7.1.1 General cable characteristics

To Minimize discontinuities and signal reflections, cables of different impedances should not be used in the same bus. Implementations may require tradeoffs in shielding effectiveness, cable length, the number of loads, transfer rates, and cost to achieve satisfactory system operation. If shielded and unshielded cables are mixed within the same SCSI bus, the effect of impedance mismatch must be carefully considered. Proper impedance matching is especially important in order to maintain adequate margin at fast SCSI transfer rates.

9.7.1.2 Single-ended drivers/receivers

The maximum total cable length allowed with drives using single-ended I/O driver and receiver circuits depends on several factors. Table 20 lists the maximum lengths allowed for different configurations of drive usage. These values are from the SPI documents. All device I/O lines must have equal to or less than 25 pF capacitance to ground, measured at the beginning of the stub.

Table 20: Cable characteristics for single-ended circuits

I/O transfer rate	Maximum number of devices on the bus	Maximum length between SCSI S.E. terminators	Transmission line impedance	
			REQ/ACK	Other signals
≤10M transfers/s (Fast-10)	16 (wide SCSI bus)	3 meters (9.8 ft)	90 ± 6 Ohms	90 ± 10 Ohms
≤20M transfers/s (Fast-20)	4 (wide SCSI bus)	3 meters (9.8 ft)	90 ± 6 Ohms	90 ± 10 Ohms
≤20M transfers/s (Fast -20)	8 (wide SCSI bus)	1.5 meters (4.9 ft)	90 ± 6 Ohms	90 ± 10 Ohms

A stub length of no more than 0.1 meter (0.33 ft) is allowed off the mainline interconnection with any connected equipment. The stub length is measured from the transceiver to the connection to the mainline SCSI bus.

Single-ended I/O cable pin assignments for LW drives are shown in Table 17.

Single-ended I/O pin assignments for LC models are shown in Table 18. The LC model does not require an I/O cable. It is designed to connect directly to a back panel connector.

9.7.1.3 Low voltage differential I/O circuits

The maximum SCSI bus length between the terminators for a SCSI LVD point-to-point system (one initiator and one target) is 25 meters.

The maximum SCSI bus length between the terminators for a SCSI LVD multidrop system (up to 16 total SCSI devices) is 12 meters (39.37 feet). However, implementation of this 12-meter total length is dependent on the configuration of the system and the choice of cable. See Tables 21 and 22 for examples of recommended SCSI LVD cable types and lengths.

Note from these tables that shielded round twister-pair cables can be used to implement a 12-meter system, while Twist-n-flat cables cannot be used to implement a 12-meter system due to higher levels of attenuation and crosstalk. In addition, twist-n-flat cables with shorter sections of twist allow greater crosstalk and their lengths must be reduced as shown in Table 22.

Table 21: Example shielded round twister pair cables into a multi-drive backplane

Cable Description	Differential Impedance, nominal	Single-ended impedance, nominal	Single-ended capacitance, maximum	Time Delay, nominal	Conductor DC resistance, nominal	Maximum shielded round twister-pair cable length for Ultra160/Ultra320
30 AWG solid	130 ohms	90 ohms	17 pF/ft	1.36 ns/ft	0.113 ohms/ft	12 meters minus the SCSI trace length of the backplane
28 AWG stranded	123 ohms	80 ohms	19 pF/ft	1.54 ns/ft	0.067 ohms/ft	12 meters minus the SCSI trace length of the backplane
28 AWG stranded	132 ohms	85 ohms	20 pF/ft	1.50 ns/ft	0.065 ohms/ft	12 meters minus the SCSI trace length of the backplane

Table 22: Example Twist-n-flat cables into a multi-drive backplane

Cable Description	Differential impedance, nominal	Single-ended impedance, nominal	Single-ended capacitance, maximum	Time Delay, nominal	Conductor DC resistance, nominal	Twist-n-flat Cable Length	
						Ultra320 transfer rate	Ultra160 transfer rate
TPE, 22.25" twist, 1.75" flat, (24" flat to flat), 30 AWG solid tinned copper	131 ohms	93 ohms	15.3 pF/ft	1.45 ns/ft	0.105 ohms/ft	3.05 meters (10.0 ft)	6.1 meters (20.0 ft)
TPE, 8.1" twist, 1.75" flat, (9.85" flat to flat), 30 AWG solid tinned copper	131 ohms	93 ohms	15.3 pF/ft	1.45 ns/ft	0.105 ohms/ft	2.45 meters (8.33 ft)	4.9 meters (16.66 ft)
TPE, 4.25" twist, 1.75" flat, (6" flat to flat), 30 AWG solid tinned copper	131 ohms	93 ohms	15.3 pF/ft	1.45 ns/ft	0.105 ohms/ft	1.52 meters (5.0 ft)	3.04 meters (10.0 ft)

9.8 Terminator requirements

Caution: These drives do not have onboard internal terminators. The user, systems integrator or host equipment manufacturer must provide a terminator arrangement external to the drive when termination is required. For LW drives, terminator modules can be purchased that plug between the SCSI I/O cable and the drive I/O connector or on the end of a short I/O cable stub extending past the last cable connector. LC drives are designed to be plugged into a backpanel connector without cabling.

9.9 Terminator power

LW drives

You can configure terminator power from the drive to the SCSI bus or have the host adaptor or other device supply terminator power to the external terminator. See Section 8.1 for illustrations that show how to place jumpers for this configuration.

LC drives

These drives cannot furnish terminator power because no conductors in the 80-pin I/O connector are devoted to terminator power.

9.10 Disc drive SCSI timing**Table 23: Disc drive SCSI timing**

These values are not current Cheetah X15 36LP values, but are listed for information only.

Description	Waveform symbol [1]	Waveform table [1]	Typical timing
Target Select Time (no Arbitration)	T00	N/A	<1 μ s
Target Select Time (with Arbitration)	T01	4.5-1,2	1.93 μ s
Target Select to Command	T02	4.5-1	3.77 μ s
Target Select to MSG Out	T03	4.5-2	1.57 μ s
Identify MSG to Command	T04	4.5-3	3.36 μ s
Command to Status	T05	4.5-5	Command Dependent
Command to Data (para. In)	T06	4.5-9	Command Dependent
Command to Data (para. Out)	T07	4.5-10	Command Dependent
Command to Data (Write to Data Buffer)	T08	4.5-10	Command Dependent
Command to Disconnect MSG	T09	4.5-6	Command Dependent
Disconnect MSG to Bus Free	T10	4.5-6,14	0.52 μ s
Disconnect to Arbitration (for Reselect) This measures disconnected CMD overhead	T11	4.5-6	Command Dependent
Target win Arbitration (for Reselect)	T12	4.5-7	3.00 μ s
Arbitration to Reselect	T13	4.5-7	1.60 μ s
Reselect to Identify MSG In	T14	4.5-7	1.39 μ s
Reselect Identify MSG to Status	T15	4.5-8	Command Dependent
Reselect Identify MSG to Data (media)	T16	4.5-11	Command Dependent
Data to Status	T17	4.5-15	Command Dependent
Status to Command Complete MSG	T18	4.5-5,8,15	0.98 μ s
Command Complete MSG to Bus Free	T19	4.5-5,8,15	0.51 μ s
Data to Save Data Pointer MSG	T20	4.5-14	4.00 μ s
Save Data Pointer MSG to Disconnect MSG	T21	4.5-14	0.79 μ s
Command Byte Transfer	T22	4.5-4	0.04 μ s
Next Command Byte Access:		4.5-4	
Next CDB Byte Access (Byte 2 of 6)	T23.6.2	4.5-4	0.58 μ s
Next CDB Byte Access (Byte 3 of 6)	T23.6.3	4.5-4	0.12 μ s
Next CDB Byte Access (Byte 4 of 6)	T23.6.4	4.5-4	0.12 μ s
Next CDB Byte Access (Byte 5 of 6)	T23.6.5	4.5-4	0.12 μ s
Next CDB Byte Access (Byte 6 of 6)	T23.6.6	4.5-4	0.12 μ s
Next CDB Byte Access (Byte 2 of 10)	T23.10.2	4.5-4	0.59 μ s
Next CDB Byte Access (Byte 3 of 10)	T23.10.3	4.5-4	0.11 μ s \pm 1 μ s
Next CDB Byte Access (Byte 4 of 10)	T23.10.4	4.5-4	0.12 μ s \pm 1 μ s
Next CDB Byte Access (Byte 5 of 10)	T23.10.5	4.5-4	0.11 μ s \pm 1 μ s
Next CDB Byte Access (Byte 6 of 10)	T23.10.6	4.5-4	0.11 μ s \pm 1 μ s
Next CDB Byte Access (Byte 7 of 10)	T23.10.7	4.5-4	0.13 μ s \pm 1 μ s
Next CDB Byte Access (Byte 8 of 10)	T23.10.8	4.5-4	0.12 μ s \pm 1 μ s
Next CDB Byte Access (Byte 9 of 10)	T23.10.9	4.5-4	0.12 μ s \pm 1 μ s

Table 23: Disc drive SCSI timing (Continued)

These values are not current Cheetah X15 36LP values, but are listed for information only.

Description	Waveform symbol [1]	Waveform table [1]	Typical timing
Next CDB Byte Access (Byte 10 of 10)	T23.10.10	4.5-4	0.12 μ s \pm 1 μ s
Data In Byte Transfer (parameter)	T24	4.5-12	0.04 μ s
Data Out Byte Transfer (parameter)	T25	4.5-13	0.04 μ s
Next Data In Byte Access (parameter)	T26	4.5-12	0.12 μ s
Next Data Out Byte Access (parameter)	T27	4.5-13	0.12 μ s
Data In Byte Transfer (media) [2]	T28	4.5-12	0.04 μ s
Data Out Byte Transfer (media) [2]	T29	4.5-13	0.04 μ s
Next Data In Byte access (media [2])	T30	4.5-12	0.12 μ s
Next Data Out Byte access (media [2])	T31	4.5-13	0.12 μ s
MSG IN Byte Transfer	T32	4.5-5,7,8,14,15	0.04 μ s
MSG OUT Byte Transfer	T33	4.5-2	0.04 μ s
STATUS Byte Transfer	T34	4.5-5,8,15	0.04 μ s
Synchronous Data Transfer Characteristics:			
Request Signal Transfer Period [3]	–	–	various (800 ns max)

Notes.

- [1] See the Timing examples section of the *SCSI Interface Product Manual*.
 [2] Maximum SCSI asynchronous interface transfer rate is given in Section 4.2.3 of this manual.
 [3] Synchronous Transfer Period is determined by negotiations between an Initiator and a Drive. The Drive is capable of setting periods as given in Section 9.5. See also the Synchronous data transfer section and the Extended messages section of the *SCSI Interface Product Manual* for a description of synchronous data transfer operation.

9.11 Drive activity LED

The following table provides drive activity LED status.

Table 24: Drive activity LED status

Spindle status	Command status	LED status
Spinning up with DC power applied	N/A	On until spinup is complete
Spun down	Start Unit	On while processing the command
Powered down by removal of DC power	N/A	Off due to absence of power
Spun up	Stop Unit	On while processing the command
Spun down	No command activity	Off
Spun down	Write/Read Buffer	On while processing the command
Spun down	SCSI Bus Reset	On while processing the reset
Spun down	Test Unit Ready	On while processing the command
Spun up	No command activity	Off
Spun up	Write/Read	On while processing the command
Spun up	SCSI Bus Reset	On while processing the reset
Spun up	Test Unit Ready	On while processing the command
Spun up	Format with Immediate option on	On while the command is initially processed
Spun up	Format without Immediate	LED toggles on/off on each cylinder boundary

10.0 Seagate Technology support services

Online Services

Internet

www.seagate.com for information about Seagate products and services. Worldwide support is available 24 hours daily by e-mail for your disc or tape questions.

Presales Support:

Disc: www.seagate.com/support/email/email_presales.html or DiscPresales@Seagate.com.

Tape: www.seagate.com/support/email/email_tape_presales.html or Tape_Sales_Support@Seagate.com.

Technical Support:

Disc: www.seagate.com/support/email/email_disc_support.html or DiscSupport@Seagate.com.

Tape: www.seagate.com/support/email/email_tape_support.html or TapeSupport@Seagate.com.

Reseller Marketplace

Reseller Marketplace is the storage industry's first collaborative, e-commerce marketplace offering resellers the fastest, most efficient online purchasing process for Seagate storage solutions. The Reseller Marketplace at marketplace.seagate.com, an exclusive service for US resellers participating in the Seagate Partner Program (SPP), is designed to streamline the purchasing process of Seagate solutions and provide unprecedented value to Seagate's resellers through real-time pricing and availability, fast and easy comparison shopping, and seamless integration with key distributors for a one-stop shopping experience.

For support, questions and comments: reseller.seagate.com/benefits/T1.html or 1-877-271-3285 (toll-free) 9 A.M. to 7 P.M. (eastern time) Monday through Friday.

Tape Purchases

US customers can purchase Seagate data cartridges, tape supplies, accessories, and select Seagate tape drive products 24 hours daily at buytape.seagate.com.

Automated Services

SeaFONE® (1-800-SEAGATE) is Seagate's toll-free number (1-800-732-4283) to access our automated self-help services. Using a touch-tone phone, you can find answers to service phone numbers, commonly asked questions, troubleshooting tips and specifications for disc drives and tape drives 24 hours daily. International callers can reach this service by dialing +1-405-936-1234.

SeaFAX® (1-800-SEAGATE) is Seagate's automated FAX delivery system. Using a touch-tone phone, you can obtain technical support information by return FAX 24 hours daily.

Presales Support

Presales Support

Our Presales Support staff can help you determine which Seagate products are best suited for your specific application or computer system.

Technical Support

If you need help installing your drive, consult your dealer. Dealers are familiar with their unique system configurations and can help you with system conflicts and other technical issues. If you need additional help, you can talk to a Seagate technical support specialist. Before calling, note your system configuration and drive model number (ST####).

SeaTDD™ (+1-405-936-1687) is a telecommunications device for the deaf (TDD). You can send questions or comments 24 hours daily and exchange messages with a technical support specialist from 8:00 A.M. to 11:45 A.M. and 1:00 P.M. to 6:00 P.M. (central time) Monday through Friday.

Customer Service (CSO)

Warranty Service

Seagate offers worldwide customer support for Seagate drives. Seagate direct OEM, Distribution and System Integrator customers should contact their Seagate service center representative for warranty information. Other customers should contact their place of purchase.

Authorized Service Centers

If you live outside the US, you can contact an Authorized Service Center for service.

USA/Canada/Latin America Support Services

Presales Support

Call Center	Toll-free	Direct dial	FAX
<i>Disc:</i>	1-877-271-3285	+405-936-1210	+1-405-936-1683
<i>Tape:</i>	1-800-626-6637	+1-714-641-2500	+1-714-641-2410

Technical Support (SeaFONE)

1-800-SEAGATE or +1-405-936-1234 (for specific product phone number)

FAX: *Disc:* +1-405-936-1685; *Tape and Server Appliance:* +1-405-936-1683

SeaFAX	1-800-SEAGATE
SeaTDD	+1-405-936-1687

Warranty Service

Call Center	Toll-free	Direct dial	FAX / Internet
USA, Mexico and Latin America	1-800-468-3472	+1-405-936-1456	+1-405-936-1462
Canada			
<i>Memofix*</i>	1-800-636-6349	+1-905-660-4936	+1-905-660-4951 www.memofix.com
<i>Adtech*</i>	1-800-624-9857	+1-905-812-8099	+1-905-812-7807 www.adtech1.com
Brazil			
<i>MA Centro de Serviços*</i>	—	+55-21-2509-7267 e-mail: centro.de.servicos.brasil@seagate.com	+55-21-2507-6672

European Support Services

For European customer support, dial the toll-free number for your specific country for presales support, technical support, SeaFAX and warranty service.

If your country is not listed here, dial our European call center at +31-20-316-7222 from 8:30 A.M. to 5:00 P.M. (European central time) Monday through Friday. The European call center is located in Amsterdam, The Netherlands.

Call Center

Austria	0 800-20 12 90
Belgium	0 800-74 876
Denmark	80 88 12 66
France	0 800-90 90 52
Germany	0 800-182 6831
Ireland	1 800-55 21 22
Italy	800-790695
Netherlands	0 800-732 4283
Norway	800-113 91
Poland	00 800-311 12 38

*Authorized Service Centers

Spain	900-98 31 24
Sweden	0 207 90 073
Switzerland	0 800-83 84 11
Turkey	00 800-31 92 91 40
United Kingdom	0 800-783 5177

FAX Services—All European Countries

Presales/Technical Support/Warranty Service 31-20-653-3513

Africa/Middle East Support Services

For presales, technical support, warranty service and FAX services in Africa and the Middle East, dial our European call center at +31-20-316-7222 from 8:30 A.M. to 5:00 P.M. (European central time) Monday through Friday, or send a FAX to +31-20-653-3513. The European call center is located in Amsterdam, The Netherlands.

Asia/Pacific Support Services

For Asia/Pacific presales and technical support, dial the toll-free number for your specific country. The Asia/Pacific toll-free numbers are available from 6:00 A.M. to 10:45 A.M. and 12:00 P.M. to 6:00 P.M. (Australian eastern time) Monday through Friday. If your country is not listed here, direct dial one of our technical support locations.

Call Center	Toll-free	Direct dial	FAX
Australia	1800-14-7201	—	—
China	—	—	+86-10-6871-4316
Hong Kong	800-90-0474	—	+852-2368 7173
Indonesia	001-803-1-003-2165	—	—
Japan	—	—	+81-3-5462-2979
Malaysia	1-800-80-2335	—	—
New Zealand	0800-443988	—	—
Singapore	800-1101-150	—	+65-6488-7528
Taiwan	—	+886-2-2514-2237	+886-2-2715-2923
Thailand	001-800-11-0032165	—	—

Warranty Service

Call Center	Toll-free	Direct dial	FAX
Asia/Pacific	—	+65-6485-3595	+65-6485-4860
Australia	1800-12-9277	—	—
Japan	—	+81-3-5462-2904	+81-3-5462-2979

Index

Symbols

+5 and +12 volt supplies 21

Numerics

68 conductor connector 59
 68-pin connector 60
 80 conductor connector 59
 80 conductor interface 59
 80 pin connector option 58
 80 pin I/O connector 65, 66

A

AC power 21
 access time 8
 accessories 7
 acoustics 30
 activity indicator 67
 activity LED 72
 actuator 6, 40
 actuator assembly 6
 address 9
 air cleanliness 30
 air flow 27, 40
 suggested 40
 air inlet 40
 altitude 27
 altitude and atmospheric pressure 27
 ambient 27
 ambient temperature 27, 40
 ANSI SCSI documents 4
 arbitration priority 60
 asynchronous interface transfer rate 72
 audible noise 3
 Australia/New Zealand Standard 4
 automatic retry 13
 automatic shipping lock 5
 average idle current 21
 average latency 6
 average rotational latency 8, 9

B

background processing 6
 backward compatibility 5
 bits/inch 8
 buffer 9, 10, 11
 buffer segment 10, 11
 buffer-full 10
 buffer-full ratio 10
 bulkhead connector 57
 bus device reset message 48
 bytes per sector 46
 bytes/surface 8
 bytes/track 8

C

cabinet cooling 40
 cable 55
 cache 9, 10, 11
 cache buffer 6
 cache miss 10
 cache mode 9
 cache operation 9
 cache operation hit 11
 cache segment 10
 caching write data 10
 Canadian Department of Communications 3
 capacities 7
 capacity, drive, programmable 7
 case temperature 27
 CE Marking 3
 changeable bit 49, 51
 changeable value 48
 check condition 48
 circuits 68
 class B limit 3
 command 9, 44
 command descriptor block (CDB) 9
 command queuing 6
 condensation 27
 conducted noise immunity 21, 22
 connect/disconnect 9
 connector 55
 connector contact 67
 consecutive read operation 11
 contiguous blocks of data 11
 continuous vibration 30
 controller 9
 controller overhead 8
 controller self test 22
 cooling 40
 C-Tick Marking 3
 current 22
 current limiting 22
 current profile 22, 23, 24
 current requirements 21
 current value 48, 49, 51
 cylinder boundary 11

D

daisy-chain 22, 57, 60
 80 conductor 59
 data correction 13
 data transfer period 54
 data transfer protocol 6
 data transfer rate 8
 DC cable and connector 55
 DC current 57
 DC power 9, 13, 55
 DC power carrying conductor 59
 DC power connector 54

- DC power requirements 21
- DC power source 59
- dedicated landing zone 5
- default 38, 39
- default mode parameter 35
- default value 48, 49, 51
- defect/error management 33
- delayed motor start option 21, 67
- depot repair 14
- depot repair philosophy 14
- diagnostics 22
- differential I/O circuit 39
- differentiating features 5
- dimensions 31
- disable read ahead 11
- disc access 10
- disc media 8
- disc rotational speed 8
- disconnect/reconnect 10
 - control 10
 - specification 10
- discontinuity (DISC) bit 11
- DRA bit 11
- drive 30
 - drive activity 67
 - drive activity LED 72
 - drive capacity 8
 - programmable 7
 - drive default mode parameter 35
 - drive failure 14
 - drive firmware 48
 - drive ID 35
 - drive ID select jumper connector 35
 - drive ID/option select header 35
 - drive interface connector 59
 - drive internal 22
 - drive internal defects and errors 33
 - drive malfunction 14
 - drive mounting 31, 41
 - constraints 13
 - drive orientation 40
 - drive power 35
 - drive primary defects list 33
 - drive SCSI timing 71
 - drive select header 54
 - drive transfer 10
 - drive volume 35
 - drive warranty 14
- dynamic spindle brake 6

E

- ECC 13
- ECC correction capability 6
- electrical characteristics 54, 67
- electromagnetic compatibility 3
- electromagnetic interference (EMI) 13
- electromagnetic susceptibility 30

- embedded servo 6
- EMC compliance 3
- EMI requirements 3
- environment 40
- environmental control 30
- environmental interference 13
- environmental limits 27
- environmental requirements 13
- EPROM 48
- equipment malfunction 13
- error 13
 - error management system 34
 - error rate 13
 - error rate calculation 13
 - error recovery 33
- ETF defect list 33
- European Union requirements 3
- EVPD bit 47
- execution time 9
- extended messages 44

F

- fault status 13
- FCC rules and regulations 3
- field repair 14
- firmware 48
- flat ribbon cable 67
- flaw reallocation 9
- format 46
 - format command 8
 - format time 9
- formatted 7
- formatting 35
- front panel 31
- front panel LED 67
- FSW function 49, 50, 51, 52

G

- GMR heads 5
- gradient 27
- ground return 21
- grounding 41

H

- hard reset 48
- hardware error 14
- HDA 5, 14, 40, 41
- head and disc assembly. See HDA
- heat removal 40
- heat source 40
- high level format 35
- host 11, 33, 46, 57, 60
 - host adapter 35
 - adapter/initiator 60
 - host backplane wiring 57
 - host equipment 41, 58, 59

DC power 59
 host I/O signal 35
 host system 35
 host system malfunction 13
 host/drive operational interface 13
 hot plug 6, 15
 humidity 27

I

I/O connector 57
 identified defect 33
 idle condition 25, 26
 Input characteristics 67
 inquiry command 47
 inquiry vital product data 47
 installation 35
 installation guide 7
 installation instructions 35
 instantaneous current peak 21
 interface cable length 60
 interface data 8
 interface requirements 43
 interface timing 13
 internal data rate 8

J

J1-auxiliary 35
 jumper 7, 35, 38, 39, 67
 jumper function description 39
 jumper header 38
 jumper plug type 35

L

landing zone 6
 LB 10
 LED 72
 logical 9
 logical block 9, 10, 11
 logical characteristics 54
 logical segment (mode select page 08h) 9
 low level format 35
 low voltage differential (LVD) drivers and receivers 6
 LVD 67
 LVD interface receiver circuits 67

M

magnetoresistive heads 5
 mating connector 55, 59
 mating flat cable connector 59
 maximum current requirements 22
 maximum operating current 21
 maximum starting current 21
 mean time between failure. See MTBF
 media 6, 48
 media defect 13
 media defect induced error 13

medium error 14
 message protocol 54
 message protocol system 34
 messages
 SCSI interface 43
 miscellaneous features 53
 mode page 01 48
 mode page 08h 9
 mode parameter 48
 page 08h 11
 mode select command 9, 48
 mode select page 08h 11
 mode sense command 48, 49, 51
 mode sense command page 08h 10
 mode sense data 48
 mode sense value 48
 model number table 5
 motor start command 9
 motor start delay option 67
 motor start option 9, 21, 67
 mounting configuration 31
 mounting configuration dimensions 31, 32
 mounting constraints 13, 41
 mounting point 41
 mounting surface 41
 mounting surface distortion 41
 mounting surface stiffness 41
 MTBF 13, 14, 27
 multimode drivers and receivers 6
 multiple segment 10
 multi-segmented cache control 9

N

noise 22
 audible 3
 non-operating 27, 28, 30
 temperature 27
 non-operating vibration 30
 nonshielded 68 conductor connector 59

O

office environment 30
 operating 27, 28, 30
 operating environment 14
 operating option 35
 operating parameter 48
 operator intervention 13
 option jumper 35
 option jumper location 35
 option select header 54
 option select jumper 35
 options 7
 orientation 9, 28, 40
 out-of-plane deflection 41
 out-of-plane distortion 41
 Output characteristics 67

P

package size 28
 package test specification 4
 packaged 28
 partition or logical drive 35
 PCB 14, 38
 PCBA 35, 41, 48, 55, 57, 60
 PCBA circuit run 57
 peak bits/inch 8
 peak starting current 21
 performance characteristics 8
 performance degradation 28
 peripheral I/O cable 22
 physical buffer space 9
 physical characteristics 54
 physical damage 30
 physical interface 54, 56
 physically contiguous blocks of data 11
 power 21, 22, 39
 power connector 21, 22
 power control switch 9
 power dissipation 25, 26
 power distribution 3
 power sequencing 22
 power supply voltage 13
 power-carrying conductor 59
 power-on 35, 67
 power-on operating hours 14
 power-on reset 48
 power-up 22
 power-up hours 14
 prefetch 9, 10, 11
 prefetch (read look-ahead) 9, 11
 prefetch ceiling field 11
 prefetch data 11
 prefetch field 11
 prefetch hit 11
 prefetch mode 9
 prefetch of contiguous blocks 11
 prefetch operation 9, 11
 prefetch segmented cache control 9
 preventive maintenance 13, 14
 PRML read channel electronics 5
 product data page 47
 programmable drive capacity 7

Q

QAS 43
 Quick Arbitration and Selection (QAS) 43

R

radio interference regulations 3
 read 10
 read command 10, 11
 read data 10
 read error 13

read error rate 13, 33
 read operation 10
 read retry count 33
 read/write head 8
 ready 48
 receive diagnostic results 34
 receiver circuits 68
 recommended mounting 29
 recoverable seek error 13
 reference documents 4
 regulation 21
 relative humidity 27
 reliability 6
 reliability and service 14
 reliability specifications 13
 remote switch 35
 repair facility 14
 repair information 19
 REQ/ACK offset 54
 request sense command 34
 request sense information 14
 resonance 28
 retrieved data 10

S

S.M.A.R.T. 7, 15
 safe power transmission 59
 safety 3
 saved value 48, 49, 51
 SCSI
 commands 44
 format commands 13
 interface data transfer rate 8
 messages 43
 SCSI bus cable 35
 SCSI bus condition 53
 SCSI bus ID 67
 SCSI bus phase sequence 53
 SCSI command 33
 SCSI I/O connector 56
 SCSI ID 35
 SCSI interface 9, 13, 57
 SCSI interface cable 58
 SCSI interface commands supported 44
 SCSI interface connector 54
 SCSI interface data 8
 SCSI Interface Product Manual 3, 4, 5
 SCSI systems error 34
 SCSI systems error consideration 33
 SCSI systems error management 34
 Seagate support service 35
 sector 10
 sector interleave 8
 sector size 7
 sector sizes 9
 seek error 13
 seek positioning error 13

segment 9, 10
 self-contained 10
 Self-Monitoring Analysis and Reporting Technology.
 See S.M.A.R.T.
 SE-LVD alternative 68
 sense key 14
 sequential read operations 11
 service
 life 13, 14
 philosophy 14
 tools 14
 servo data 6
 shielding 3
 shipping 19
 shipping container 27
 shock 28
 and vibration 28
 shock mount 41
 signal ground 41
 single unit shipping pack 7
 single-ended (SE) drivers and receivers 6
 single-ended interface circuit 25, 26
 site installation 14
 software interleave 11
 spare part 14
 spindle 22
 standard day 27
 standards 3
 start motor command 21
 start/stop time 9
 status 34
 stop spindle 9
 stop time 9
 storage capacity 33
 straight-in connector 60
 strict bit in Mode page 00h 10
 supply voltage 21
 support services 73
 synchronous data transfer 54
 synchronous data transfer operation 72
 synchronous data transfer period 54
 synchronous transfer period 72
 system chassis 41
 system recovery procedures 13

T

technical support services 73
 temperature 9, 16, 27, 40
 ambient 27
 case 27
 gradient 27
 non-operating 27
 regulation 3
 See *also* cooling
 temperature sensor 17
 termination 22
 terminator enable jumper TE 60

terminator power 70
 terminator requirements 35, 70
 thermal monitor 16
 TP1 position 39
 tracks/inch 8
 tracks/surface, total 8
 transfer period 54
 transmitter receiver circuits 68
 typical access time 9

U

Ultra160 49, 51
 Ultra160 mode 44
 Ultra160 SCSI interface 5
 Ultra320 mode 44
 unformatted 7
 unrecoverable condition 13
 unrecoverable error 13
 unrecoverable seek error 14
 Unrecoverable write error 13

V

vibration 28, 30
 vital product data 47
 volatile memory 48
 voltage 9, 21

W

warranty 7, 19
 wet bulb temperature 27
 wide Ultra160 SCSI interface 5
 wrap-around 10
 write caching 10
 write error 13
 unrecoverable 13
 write operation 10
 write protect 39
 write retry count 33

Z

zoned bit recording (ZBR) 6



Seagate Technology LLC
920 Disc Drive, Scotts Valley, California 95066-4544, USA
Publication Number: 100139872, Rev. D, Printed in USA